

ESPECIFICACIONES TÉCNICAS

HOOK 3



DATOS TÉCNICOS

HOOK 3			21	23	25	27	29
ALVÉOLOS	NÚMERO		52	52	52	52	52
	CERRADOS		8	8	8	8	8
	CAJONES		23	23	23	23	23
EN PLANTA	ÁREA	M2	21	23	25	27	29
	ENVERGADURA	M	10,65	11,15	11,62	12,08	12,51
	ALARGAMIENTO		5,4	5,4	5,4	5,4	5,4
PROYECTADO	ÁREA	M2	17,85	19,55	21,25	22,95	24,65
	ENVERGADURA		8,45	8,84	9,22	9,58	9,93
	ALARGAMIENTO		4	4	4	4	4
BÓVEDA		%	15	15	15	15	15
CUERDA	MÁXIMA		2,47	2,58	2,69	2,8	2,9
	MÍNIMA		0,49	0,52	0,54	0,56	0,58
	MEDIA		1,97	2,06	2,14	2,23	2,31
SUSPENTES	METROS TOTALES M		208	218	227	236	245
	ALTURA	M	6,5	6,8	7,09	7,36	7,63
	NÚMERO		180	180	180	180	180
	PRINCIPALES		A/B/C	A/B/C	A/B/C	A/B/C	A/B/C
ELEVADORES	BANDAS	3	3/3/2	3/3/2	3/3/2	3/3/2	3/3/2
	TRIMS		NO	NO	NO	NO	NO
	ACELERADOR	m/m	150	150	150	150	150
CARGA TOTAL	MÁXIMO	KG	59	65	80	95	110
EN VUELO	MÍNIMO	KG	70	85	100	115	130
PESO DEL ALA		KG	4,65	4,9	5,3	5,5	5,85
HOMOLOGACIÓN	EN / LTF	B	B	B	B	B	B

DATOS TÉCNICOS MATERIALES

VELA	REFERENCIA	FABRICANTE
EXTRADÓS	9017 E77A	PORCHER IND (FRANCE)
INTRADÓS	N-20-DMF	DOMINICO TEX CO (KOREA)
PERFILES	9017 E29	PORCHER IND (FRANCE)
DIAGONALES	9017 E29	PORCHER IND (FRANCE)
CINTAS DE CARGA	LKI - 10	KOLON IND. (KOREA)
REFUERZOS CARGA PERFIL	W-420	D-P (GERMANY)
REFUERZOS BORDE DE FUGA	MYLAR	D-P (GERMANY)
REFUERZOS PERFIL	NYLON STICK	R.P.CHINA
HILO	SERAFIL 60	AMAN (GERMANY)

SUSPENTES	REFERENCIA	FABRICANTE
CONO ALTO	DC - 060	LIROS GMHB (GERMANY)
CONO ALTO	TNL - 080	TEIJIM LIMITED (JAPAN)
CONO ALTO	DC - 100	LIROS GMHB (GERMANY)
CONO MEDIO	TNL - 080	TEIJIM LIMITED (JAPAN)
CONO MEDIO	TNL - 140	TEIJIM LIMITED (JAPAN)
CONO MEDIO	TNL - 280	TEIJIM LIMITED (JAPAN)
CONO MEDIO	TNL - 400	TEIJIM LIMITED (JAPAN)
PRINCIPAL	TNL - 080	TEIJIM LIMITED (JAPAN)
PRINCIPAL	TNL - 140	TEIJIM LIMITED (JAPAN)
PRINCIPAL	TNL - 220	TEIJIM LIMITED (JAPAN)
PRINCIPAL	TNL - 400	TEIJIM LIMITED (JAPAN)
FRENO PRINCIPAL	TNL - 400	TEIJIM LIMITED (JAPAN)
HILO	SERAFIL 60	AMAN (GERMANY)

ELEVADORES	REFERENCIA	FABRICANTE
BANDAS	G-R 18	TECNI SANGLES (FRANCE)
INDICADOR DE COLOR	PAD	TECNI SANGLES (FRANCE)
HILO	V138	COATS (ENGLAND)
MAILLONES	MRI4	ANSUNG PRECISION (KOREA)
MAILLONES	MRDI03.0 S10	PEGUET (FRANCE)
POLEAS	PY - 1304-2	ANSUNG PRECISION (KOREA)
POLEAS	467	HARKEN (USA)

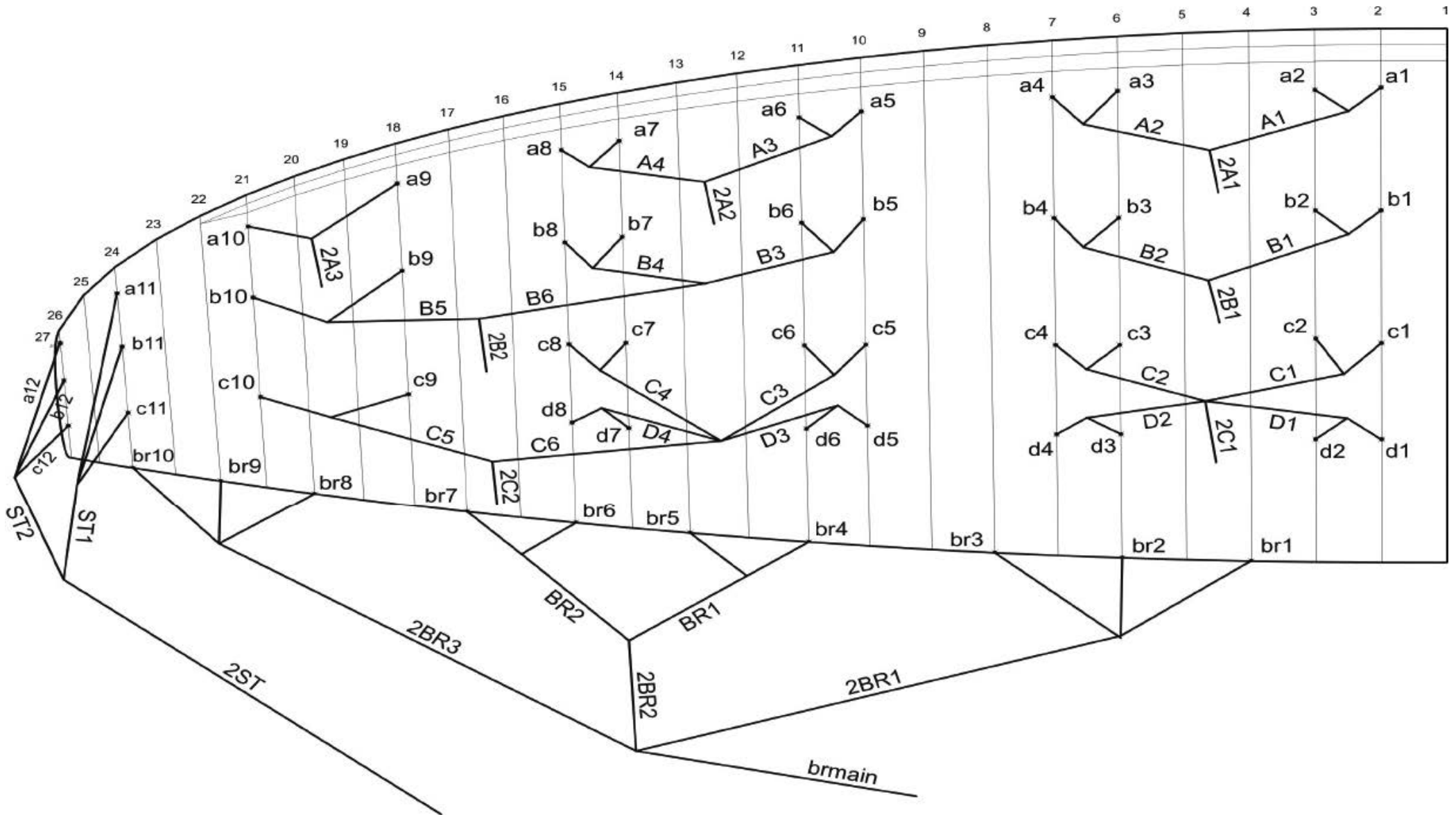

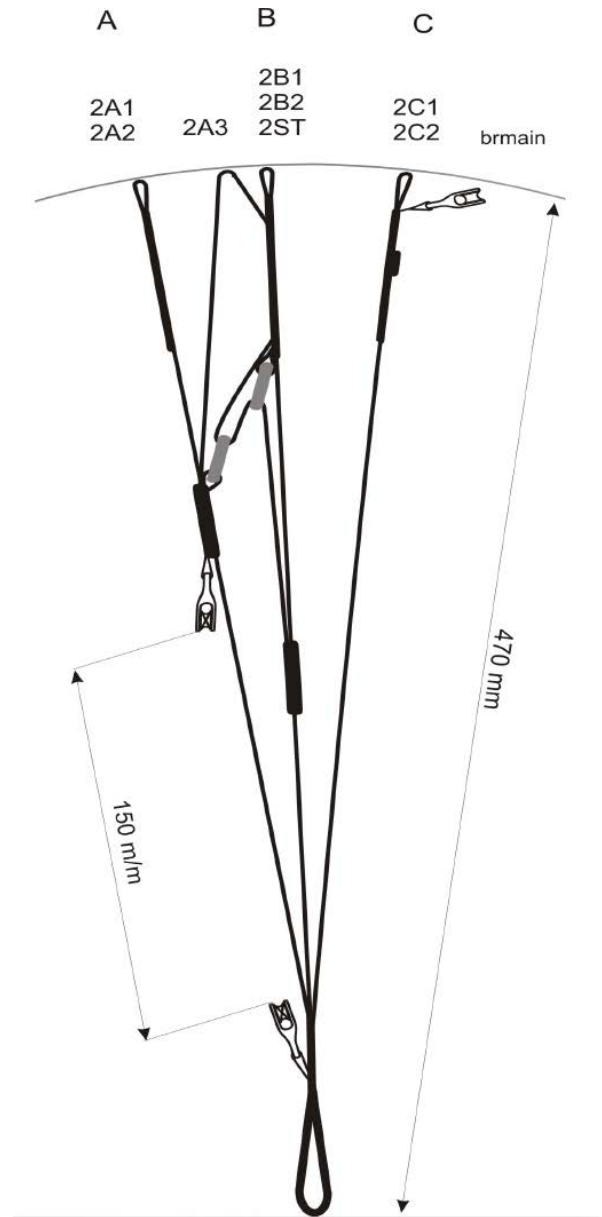

DATOS TÉCNICOS COLORES

DRAGON	1	DRAGON RED	EXTRADÓS	REF: 636
	2	GREY BLUE	CUERNO	REF: 303
	3	WHITE	SOMBRA	REF: 001
	4	DRAGON RED	INTRADÓS	REF: 636
	5	GOLD	SOMBRA CENTRAL	REF: 939



MELON	1	GOLD	EXTRADÓS	REF: 939
	2	DRAGON RED	CUERNO	REF: 636
	3	WHITE	SOMBRA	REF: 001
	4	GOLD	INTRADÓS	REF: 939
	5	GREY BLUE	SOMBRA CENTRAL	REF: 303



RUBI	1	RUBI	EXTRADÓS	REF: 200
	2	GOLD	CUERNO	REF: 939
	3	WHITE	SOMBRA	REF: 001
	4	RUBI	INTRADÓS	REF: 200
	5	BLACK	SOMBRA CENTRAL	REF: 102



STORM	1	GREY BLUE	EXTRADÓS	REF: 303
	2	ORANGE	CUERNO	REF: 744
	3	WHITE	SOMBRA	REF: 001
	4	GREY BLUE	INTRADÓS	REF: 303
	5	GOLD	SOMBRA CENTRAL	REF: 939



CARGA ALAR

HOOK 3

21		23		25		27		29	
P.T.V.	KG/M2	P.T.V.	KG/M2	P.T.V.	KG/M2	P.T.V.	KG/M2	P.T.V.	KG/M2
59	= 2,81	65	= 2,83	80	= 3,20	95	= 3,52	110	= 3,79
60	= 2,86	66	= 2,87	81	= 3,24	96	= 3,56	111	= 3,83
61	= 2,90	67	= 2,91	82	= 3,28	97	= 3,59	112	= 3,86
62	= 2,95	68	= 2,96	83	= 3,32	98	= 3,63	113	= 3,90
63	= 3,00	69	= 3,00	84	= 3,36	99	= 3,67	114	= 3,93
64	= 3,05	70	= 3,04	85	= 3,40	100	= 3,70	115	= 3,97
65	= 3,10	71	= 3,09	86	= 3,44	101	= 3,74	116	= 4,00
66	= 3,14	72	= 3,13	87	= 3,48	102	= 3,78	117	= 4,03
67	= 3,19	73	= 3,17	88	= 3,52	103	= 3,81	118	= 4,07
68	= 3,24	74	= 3,22	89	= 3,56	104	= 3,85	119	= 4,10
69	= 3,29	75	= 3,26	90	= 3,60	105	= 3,89	120	= 4,14
70	= 3,33	76	= 3,30	91	= 3,64	106	= 3,93	121	= 4,17
		77	= 3,35	92	= 3,68	107	= 3,96	122	= 4,21
		78	= 3,39	93	= 3,72	108	= 4,00	123	= 4,24
		79	= 3,43	94	= 3,76	109	= 4,04	124	= 4,28
		80	= 3,48	95	= 3,80	110	= 4,07	125	= 4,31
		81	= 3,52	96	= 3,84	111	= 4,11	126	= 4,34
		82	= 3,57	97	= 3,88	112	= 4,15	127	= 4,38
		83	= 3,61	98	= 3,92	113	= 4,19	128	= 4,41
		84	= 3,65	99	= 3,96	114	= 4,22	129	= 4,45
		85	= 3,70	100	= 4,00	115	= 4,26	130	= 4,48

DATOS TÉCNICOS SUSPENTES

HOOK 3			21											
REF.	CODE	m/m	REF.	CODE	m/m	REF.	CODE	m/m	REF.	CODE	m/m	REF.	CODE	m/m
A			B			C			D			BRAKE		
a1	DC-60-wht	345	b1	DC-60-wht	340	c1	DC-60-wht	295	d1	DC-60-wht	359	br1	TNL-80-red	1.447
a2	DC-60-wht	284	b2	DC-60-wht	280	c2	DC-60-wht	209	d2	DC-60-wht	277	br2	TNL-80-red	1.131
a3	DC-60-wht	307	b3	DC-60-wht	301	c3	DC-60-wht	235	d3	DC-60-wht	306	br3	TNL-80-red	970
a4	DC-60-wht	326	b4	DC-60-wht	322	c4	DC-60-wht	279	d4	DC-60-wht	346	br4	TNL-80-red	716
a5	DC-60-wht	320	b5	DC-60-wht	318	c5	DC-60-wht	275	d5	DC-60-wht	337	br5	TNL-80-red	590
a6	DC-60-wht	281	b6	DC-60-wht	266	c6	DC-60-wht	200	d6	DC-60-wht	258	br6	TNL-80-red	565
a7	DC-60-wht	272	b7	DC-60-wht	270	c7	DC-60-wht	214	d7	DC-60-wht	277	br7	TNL-80-red	628
a8	DC-60-wht	287	b8	DC-60-wht	280	c8	DC-60-wht	239	d8	DC-60-wht	296	br8	TNL-80-red	852
a9	DC-60-wht	1.490	b9	DC-60-wht	1.332	c9	DC-60-wht	903				br9	TNL-80-red	781
a10	DC-60-wht	1.351	b10	DC-60-wht	1.300	c10	DC-60-wht	925				br10	TNL-80-red	771
a11	DC-60-wht	889	b11	DC-60-wht	878	c11	DC-60-wht	977						
a12	DC-60-wht	1.041	b12	DC-60-wht	1.047	c12	DC-60-wht	1.105						
A1	TNL-140-green	1.871	B1	TNL-140-blue	1.840	C1	TNL-80-blue	1.197	D1	TNL-80-blue	1.232	BR1	TNL-80-red	754
A2	TNL-140-green	1.808	B2	TNL-140-blue	1.781	C2	TNL-80-blue	1.126	D2	TNL-80-blue	1.154	BR2	TNL-80-red	739
A3	TNL-140-green	1.731	B3	TNL-140-blue	1.579	C3	TNL-80-blue	1.124	D3	TNL-80-blue	1.147			
A4	TNL-140-green	1.690	B4	TNL-140-blue	1.495	C4	TNL-80-blue	1.007	D4	TNL-80-blue	1.017			
			B5	TNL-80-blue	1.678	C5	TNL-140-blue	1.453						
			ST1	TNL-80-red	840									
			ST2	TNL-80-red	586									
			B6	TNL-220-blue	1.329	C6	TNL-220-blue	1.195						
2A1	TNL-280-green	3.793	2B1	TNL-280-blue	3.724	2C1	TNL-280-blue	4.506				2BR1	TNL-80-red	2.856
2A2	TNL-280-green	3.839	2B2	TNL-280-blue	2.622	2C2	TNL-400-blue	3.340				2BR2	TNL-80-red	2.241
2A3	TNL-140-green	4.153	2ST	TNL-80-red	3.557							2BR3	TNL-80-red	2.574
												brmain	TNL-400-red	2.603
													Marca nudo:	2.403

DATOS TÉCNICOS SUSPENTES

HOOK 3

23

REF.	CODE	m/m	REF.	CODE	m/m	REF.	CODE	m/m	REF.	CODE	m/m	REF.	CODE	m/m
A			B			C			D			BRAKE		
a1	DC-60-wht	361	b1	DC-60-wht	355	c1	DC-60-wht	308	d1	DC-60-wht	376	br1	TNL-80-red	1.514
a2	DC-60-wht	297	b2	DC-60-wht	293	c2	DC-60-wht	219	d2	DC-60-wht	290	br2	TNL-80-red	1.184
a3	DC-60-wht	321	b3	DC-60-wht	315	c3	DC-60-wht	245	d3	DC-60-wht	320	br3	TNL-80-red	1.017
a4	DC-60-wht	341	b4	DC-60-wht	337	c4	DC-60-wht	292	d4	DC-60-wht	362	br4	TNL-80-red	750
a5	DC-60-wht	335	b5	DC-60-wht	333	c5	DC-60-wht	288	d5	DC-60-wht	353	br5	TNL-80-red	618
a6	DC-60-wht	294	b6	DC-60-wht	278	c6	DC-60-wht	209	d6	DC-60-wht	271	br6	TNL-80-red	591
a7	DC-60-wht	284	b7	DC-60-wht	282	c7	DC-60-wht	224	d7	DC-60-wht	290	br7	TNL-80-red	657
a8	DC-60-wht	301	b8	DC-60-wht	293	c8	DC-60-wht	251	d8	DC-60-wht	309	br8	TNL-80-red	892
a9	DC-60-wht	1.560	b9	DC-60-wht	1.393	c9	DC-60-wht	945				br9	TNL-80-red	817
a10	DC-60-wht	1.414	b10	DC-60-wht	1.361	c10	DC-60-wht	968				br10	TNL-80-red	807
a11	DC-60-wht	930	b11	DC-60-wht	919	c11	DC-60-wht	1.023						
a12	DC-60-wht	1.089	b12	DC-60-wht	1.096	c12	DC-60-wht	1.156						
A1	TNL-140-green	1.958	B1	TNL-140-blue	1.925	C1	TNL-80-blue	1.253	D1	TNL-80-blue	1.294	BR1	TNL-80-red	788
A2	TNL-140-green	1.894	B2	TNL-140-blue	1.866	C2	TNL-80-blue	1.180	D2	TNL-80-blue	1.204	BR2	TNL-80-red	775
A3	TNL-140-green	1.811	B3	TNL-140-blue	1.652	C3	TNL-80-blue	1.176	D3	TNL-80-blue	1.200			
A4	TNL-140-green	1.769	B4	TNL-140-blue	1.565	C4	TNL-80-blue	1.054	D4	TNL-80-blue	1.065			
			B5	TNL-80-blue	1.757	C5	TNL-140-blue	1.521						
			ST1	TNL-80-red	879									
			ST2	TNL-80-red	612									
			B6	TNL-220-blue	1.391	C6	TNL-220-blue	1.250						
2A1	TNL-280-green	3.994	2B1	TNL-280-blue	3.922	2C1	TNL-280-blue	4.720				2BR1	TNL-80-red	2.986
2A2	TNL-280-green	4.046	2B2	TNL-280-blue	2.772	2C2	TNL-400-blue	3.535				2BR2	TNL-80-red	2.346
2A3	TNL-140-green	4.375	2ST	TNL-80-red	3.752							2BR3	TNL-80-red	2.718
												brmain	TNL-400-red	2.747
													Marca nudo:	2.547

DATOS TÉCNICOS SUSPENTES

HOOK 3			25											
REF.	CODE	m/m	REF.	CODE	m/m	REF.	CODE	m/m	REF.	CODE	m/m	REF.	CODE	m/m
A			B			C			D			BRAKE		
a1	DC-60-wht	376	b1	DC-60-wht	370	c1	DC-60-wht	321	d1	DC-60-wht	392	br1	TNL-80-red	1.578
a2	DC-60-wht	311	b2	DC-60-wht	306	c2	DC-60-wht	229	d2	DC-60-wht	303	br2	TNL-80-red	1.235
a3	DC-60-wht	334	b3	DC-60-wht	328	c3	DC-60-wht	256	d3	DC-60-wht	333	br3	TNL-80-red	1.061
a4	DC-60-wht	356	b4	DC-60-wht	352	c4	DC-60-wht	305	d4	DC-60-wht	378	br4	TNL-80-red	781
a5	DC-60-wht	349	b5	DC-60-wht	347	c5	DC-60-wht	300	d5	DC-60-wht	368	br5	TNL-80-red	645
a6	DC-60-wht	306	b6	DC-60-wht	290	c6	DC-60-wht	218	d6	DC-60-wht	282	br6	TNL-80-red	615
a7	DC-60-wht	296	b7	DC-60-wht	294	c7	DC-60-wht	234	d7	DC-60-wht	302	br7	TNL-80-red	685
a8	DC-60-wht	314	b8	DC-60-wht	306	c8	DC-60-wht	261	d8	DC-60-wht	323	br8	TNL-80-red	929
a9	DC-60-wht	1.626	b9	DC-60-wht	1.452	c9	DC-60-wht	985				br9	TNL-80-red	852
a10	DC-60-wht	1.474	b10	DC-60-wht	1.419	c10	DC-60-wht	1.009				br10	TNL-80-red	842
a11	DC-60-wht	970	b11	DC-60-wht	958	c11	DC-60-wht	1.066						
a12	DC-60-wht	1.135	b12	DC-60-wht	1.143	c12	DC-60-wht	1.205						
A1	TNL-140-green	2.040	B1	TNL-140-blue	2.007	C1	TNL-80-blue	1.305	D1	TNL-80-blue	1.344	BR1	TNL-80-red	821
A2	TNL-140-green	1.977	B2	TNL-140-blue	1.947	C2	TNL-80-blue	1.231	D2	TNL-80-blue	1.263	BR2	TNL-80-red	808
A3	TNL-140-green	1.887	B3	TNL-140-blue	1.723	C3	TNL-80-blue	1.226	D3	TNL-80-blue	1.251			
A4	TNL-140-green	1.845	B4	TNL-140-blue	1.632	C4	TNL-80-blue	1.099	D4	TNL-80-blue	1.111			
			B5	TNL-80-blue	1.832	C5	TNL-140-blue	1.587						
			ST1	TNL-80-red	916									
			ST2	TNL-80-red	638									
			B6	TNL-220-blue	1.449	C6	TNL-220-blue	1.303						
2A1	TNL-280-green	4.186	2B1	TNL-280-blue	4.111	2C1	TNL-280-blue	4.964				2BR1	TNL-80-red	3.110
2A2	TNL-280-green	4.243	2B2	TNL-280-blue	2.916	2C2	TNL-400-blue	3.711				2BR2	TNL-80-red	2.446
2A3	TNL-140-green	4.587	2ST	TNL-80-red	3.938							2BR3	TNL-80-red	2.812
												brmain	TNL-400-red	2.855
													Marca nudo:	2.655

DATOS TÉCNICOS SUSPENTES

HOOK 3

27

REF.	CODE	m/m	REF.	CODE	m/m	REF.	CODE	m/m	REF.	CODE	m/m	REF.	CODE	m/m
A			B			C			D			BRAKE		
a1	DC-60-wht	390	b1	DC-60-wht	385	c1	DC-60-wht	334	d1	DC-60-wht	407	br1	TNL-80-red	1.640
a2	DC-60-wht	323	b2	DC-60-wht	318	c2	DC-60-wht	238	d2	DC-60-wht	316	br2	TNL-80-red	1.284
a3	DC-60-wht	347	b3	DC-60-wht	341	c3	DC-60-wht	265	d3	DC-60-wht	346	br3	TNL-80-red	1.104
a4	DC-60-wht	370	b4	DC-60-wht	366	c4	DC-60-wht	317	d4	DC-60-wht	393	br4	TNL-80-red	812
a5	DC-60-wht	363	b5	DC-60-wht	361	c5	DC-60-wht	312	d5	DC-60-wht	382	br5	TNL-80-red	670
a6	DC-60-wht	319	b6	DC-60-wht	301	c6	DC-60-wht	227	d6	DC-60-wht	293	br6	TNL-80-red	639
a7	DC-60-wht	308	b7	DC-60-wht	306	c7	DC-60-wht	243	d7	DC-60-wht	314	br7	TNL-80-red	712
a8	DC-60-wht	326	b8	DC-60-wht	318	c8	DC-60-wht	272	d8	DC-60-wht	335	br8	TNL-80-red	965
a9	DC-60-wht	1.690	b9	DC-60-wht	1.509	c9	DC-60-wht	1.023				br9	TNL-80-red	886
a10	DC-60-wht	1.532	b10	DC-60-wht	1.475	c10	DC-60-wht	1.049				br10	TNL-80-red	876
a11	DC-60-wht	1.008	b11	DC-60-wht	995	c11	DC-60-wht	1.107						
a12	DC-60-wht	1.180	b12	DC-60-wht	1.187	c12	DC-60-wht	1.252						
A1	TNL-140-green	2.120	B1	TNL-140-blue	2.085	C1	TNL-140-blue	1.356	D1	TNL-80-blue	1.396	BR1	TNL-80-red	853
A2	TNL-140-green	2.056	B2	TNL-140-blue	2.025	C2	TNL-140-blue	1.281	D2	TNL-80-blue	1.307	BR2	TNL-80-red	841
A3	TNL-140-green	1.961	B3	TNL-140-blue	1.790	C3	TNL-80-blue	1.273	D3	TNL-80-blue	1.299			
A4	TNL-140-green	1.918	B4	TNL-140-blue	1.696	C4	TNL-80-blue	1.143	D4	TNL-80-blue	1.155			
			B5	TNL-80-blue	1.905	C5	TNL-140-blue	1.650						
			ST1	TNL-80-red	952									
			ST2	TNL-80-red	662									
			B6	TNL-220-blue	1.498	C6	TNL-220-blue	1.353						
2A1	TNL-280-green	4.371	2B1	TNL-280-blue	4.293	2C1	TNL-400-blue	5.180				2BR1	TNL-80-red	3.230
2A2	TNL-280-green	4.433	2B2	TNL-280-blue	3.046	2C2	TNL-400-blue	3.868				2BR2	TNL-80-red	2.543
2A3	TNL-140-green	4.792	2ST	TNL-80-red	4.117							2BR3	TNL-80-red	2.926
												brmain	TNL-400-red	2.998
													Marca nudo:	2.798

DATOS TÉCNICOS SUSPENTES

HOOK 3

29

REF.	CODE	m/m	REF.	CODE	m/m	REF.	CODE	m/m	REF.	CODE	m/m	REF.	CODE	m/m
A			B			C			D			BRAKE		
a1	DC-100-wht	405	b1	DC-100-wht	399	c1	DC-60-wht	346	d1	DC-60-wht	422	br1	TNL-80-red	1.700
a2	DC-100-wht	335	b2	DC-100-wht	330	c2	DC-60-wht	247	d2	DC-60-wht	327	br2	TNL-80-red	1.331
a3	DC-100-wht	359	b3	DC-100-wht	353	c3	DC-60-wht	275	d3	DC-60-wht	359	br3	TNL-80-red	1.145
a4	DC-100-wht	384	b4	DC-100-wht	379	c4	DC-60-wht	328	d4	DC-60-wht	407	br4	TNL-80-red	841
a5	DC-100-wht	376	b5	DC-100-wht	374	c5	DC-60-wht	323	d5	DC-60-wht	396	br5	TNL-80-red	695
a6	DC-60-wht	330	b6	DC-60-wht	313	c6	DC-60-wht	235	d6	DC-60-wht	304	br6	TNL-80-red	662
a7	DC-60-wht	319	b7	DC-60-wht	317	c7	DC-60-wht	251	d7	DC-60-wht	325	br7	TNL-80-red	738
a8	DC-60-wht	338	b8	DC-60-wht	329	c8	DC-60-wht	282	d8	DC-60-wht	348	br8	TNL-80-red	1.000
a9	DC-60-wht	1.752	b9	DC-60-wht	1.564	c9	DC-60-wht	1.060				br9	TNL-80-red	918
a10	DC-60-wht	1.588	b10	DC-60-wht	1.529	c10	DC-60-wht	1.088				br10	TNL-80-red	908
a11	DC-60-wht	1.045	b11	DC-60-wht	1.031	c11	DC-60-wht	1.148						
a12	DC-60-wht	1.223	b12	DC-60-wht	1.231	c12	DC-60-wht	1.298						
A1	TNL-220-green	2.196	B1	TNL-220-blue	2.160	C1	TNL-140-blue	1.405	D1	TNL-80-blue	1.446	BR1	TNL-80-red	883
A2	TNL-220-green	2.132	B2	TNL-220-blue	2.100	C2	TNL-140-blue	1.329	D2	TNL-80-blue	1.361	BR2	TNL-80-red	872
A3	TNL-140-green	2.032	B3	TNL-140-blue	1.855	C3	TNL-80-blue	1.319	D3	TNL-80-blue	1.346			
A4	TNL-140-green	1.989	B4	TNL-140-blue	1.759	C4	TNL-80-blue	1.185	D4	TNL-80-blue	1.197			
			B5	TNL-80-blue	1.975	C5	TNL-140-blue	1.710						
			ST1	TNL-80-red	986									
			ST2	TNL-80-red	686									
			B6	TNL-220-blue	1.560	C6	TNL-220-blue	1.402						
2A1	TNL-400-green	4.549	2B1	TNL-400-blue	4.468	2C1	TNL-400-blue	5.390				2BR1	TNL-80-red	3.345
2A2	TNL-280-green	4.616	2B2	TNL-280-blue	3.195	2C2	TNL-400-blue	4.043				2BR2	TNL-80-red	2.635
2A3	TNL-140-green	4.988	2ST	TNL-80-red	4.290							2BR3	TNL-80-red	3.031
												brmain	TNL-400-red	3.126
													Point a :	2.926

NIVIUK HOOK 3 21

LONGITUD LÍNEAS m/m					
	A	B	C	D	br
1	6014	5909	6003	6103	6716
2	5954	5849	5917	6021	6400
3	5914	5812	5872	5971	6239
4	5933	5832	5916	6011	6124
5	5895	5853	5939	6024	5998
6	5856	5801	5863	5945	5958
7	5806	5720	5761	5834	6021
8	5821	5731	5786	5853	5830
9	5648	5636	5701		5758
10	5508	5604	5723		5748
11	5292	5281	5380		
12	5189	5195	5253		

LONGITUD BANDAS m/m				
	A	B	C	D
	470	470	470	ESTÁNDAR
	340	375	470	ACELERADO

NIVIUK HOOK 3 23

LONGITUD LÍNEAS m/m					
	A	B	C	D	br
1	6313	6202	6301	6410	7047
2	6249	6140	6212	6324	6717
3	6209	6103	6165	6264	6550
4	6229	6125	6212	6306	6431
5	6192	6148	6249	6338	6299
6	6151	6093	6170	6256	6259
7	6099	6010	6063	6140	6325
8	6116	6021	6090	6159	6157
9	5935	5922	6001		6082
10	5789	5890	6024		6072
11	5561	5550	5654		
12	5453	5460	5520		

LONGITUD BANDAS m/m				
	A	B	C	D
	470	470	470	ESTÁNDAR
	320	370	470	ACELERADO

NIVIUK HOOK 3 25

LONGITUD LÍNEAS m/m					
	A	B	C	D	br
1	6602	6488	6591	6700	7343
2	6537	6424	6498	6611	7000
3	6497	6386	6451	6560	6826
4	6519	6410	6500	6604	6703
5	6480	6434	6532	6626	6567
6	6437	6377	6451	6540	6525
7	6384	6291	6340	6423	6595
8	6402	6302	6368	6441	6396
9	6213	6200	6276		6319
10	6061	6167	6301		6309
11	5825	5812	5920		
12	5712	5719	5781		

LONGITUD BANDAS m/m				
	A	B	C	D
	470	470	470	ESTÁNDAR
	320	370	470	ACELERADO

NIVIUK HOOK 3 27

LONGITUD LÍNEAS m/m					
	A	B	C	D	br
1	6881	6762	6870	6983	7667
2	6814	6696	6774	6891	7311
3	6774	6658	6726	6834	7131
4	6797	6683	6778	6880	7005
5	6756	6695	6806	6903	6863
6	6712	6636	6722	6814	6820
7	6659	6546	6607	6690	6894
8	6677	6558	6636	6712	6689
9	6482	6461	6541		6610
10	6324	6426	6567		6600
11	6077	6064	6177		
12	5960	5967	6032		

LONGITUD BANDAS m/m				
	A	B	C	D
	470	470	470	ESTÁNDAR
	320	370	470	ACELERADO

LONGITUD LÍNEAS m/m

	A	B	C	D	br
1	7150	7027	7138	7256	7970
2	7081	6959	7039	7161	7601
3	7040	6921	6991	7108	7415
4	7065	6947	7045	7156	7285
5	7023	6975	7075	7176	7139
6	6978	6914	6988	7084	7095
7	6923	6822	6869	6955	7172
8	6942	6834	6900	6978	6967
9	6740	6725	6801		6885
10	6576	6690	6829		6875
11	6321	6307	6424		
12	6199	6207	6274		

LONGITUD BANDAS m/m

	A	B	C	D	
	470	470	470		ESTÁNDAR
	320	370	470		ACELERADO

DATOS TÉCNICOS SUSPENTAJE

HOOK 3

CÓDIGO MATERIAL		DC	DC	TNL	TNL	TNL	TNL	TNL
CÓDIGO CARGA		060	100	080	140	220	280	400
DIÁMETRO m/m	∅	0,6	0,8	1,1	1,4	1,6	1,8	2,3
MATERIAL ALMA		DYNEEMA	DYNEEMA	TECHNORA	TECHNORA	TECHNORA	TECHNORA	TECHNORA
MATERIAL FUNDA		NO	NO	Polyester	Polyester	Polyester	Polyester	Polyester
PESO G/M	TOTAL	0,24	0,42	1,1	1,96	2,35	2,7	4
CARGA DE RUPTURA	MÍNIMA	60	100	80	140	220	280	314
	MÁXIMA	84	110	92	160	250	320	360
RESISTENCIA DESPUÉS								
DE 5.000 CICLOS	TEST EN	74	99	36,7	76,1	114,2	134,7	184,4
DE TORSIÓN								
ALARGAMIENTO A	5 daN en %			0,3	0,2	0,2	0,2	0,05
	10 daN en %	0,43	0,36	0,5	0,3	0,3	0,3	0,1
	15 daN en %			0,7	0,5	0,5	0,4	0,2
	20 daN en %			1	0,6	0,6	0,4	0,2
	25 daN en %			1,3	0,8	0,7	0,5	0,3
	30 daN en %	1,2	1	2,3	1,5	1,2	0,9	0,6
	75 daN en %			2,8	2,3	1,8	1,3	0,8
	100 daN en %				2,7	2,2	1,7	1,1
	125 daN en %				3,2	2,7	2	1,4
	150 daN en %					3	2,3	1,7
	175 daN en %					3,3	2,7	2
	200 daN en %					3,8	2,8	2,2
	250 daN en %							
Alargamiento con carga máxima %		3,2	3,4	3	3,4	4	4,1	4,6

DATOS TÉCNICOS MAILLON

DESCRIPCIÓN

MAILLON	DELTA	MAILLON	DELTA
REFERENCIA	MRI4	REFERENCIA	MRDI03.0 S10
MATERIAL	ACERO INOXIDABLE	MATERIAL	ACERO INOXIDABLE
DIÁMETRO	4,3 m/m	DIÁMETRO	3 m/m
PESO	12 G/PIEZA	PESO	5 G/PIEZA

ESPECIFICACIONES TÉCNICAS

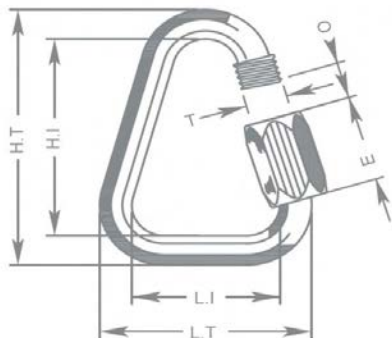

DIMENSIONES	m/m	DIMENSIONES	m/m
L.T.	28	L.T.	18
L.I.	20	L.I.	12
H.T.	38	H.T.	29
H.I.	30	H.I.	23
O	4	O	4
E	11	E	9
T	4	T	4
CARGA	KG	CARGA	KG
TRABAJO	150	TRABAJO	110
ROTURA	750	ROTURA	550

MATERIAL

AISI 304 ACERO INOXIDABLE STANDARD

CIERRE MANUAL Y TOTALMENTE ENROSCADO

PARA GARANTIZAR LA MÁXIMA SEGURIDAD (LA ROSCA NO DEBE SER VISIBLE)

CONTROL SISTEMÁTICO DE LOS CIERRES DE CADA MAILLON ANTES DE CADA VUELO.

DESCRIPCIÓN POLEA

POLEA	16 m/m
REFERENCIA	467
MATERIAL	ACERO INOXIDABLE
COJINETE	DELRIN®
PESO	12 G/PIEZA

ESPECIFICACIONES TÉCNICAS

DIMENSIONES	m/m
L.T.	16
L.I.	16
H.T.	37
ø	4 max
CARGA	KG
TRABAJO	113
ROTURA	339

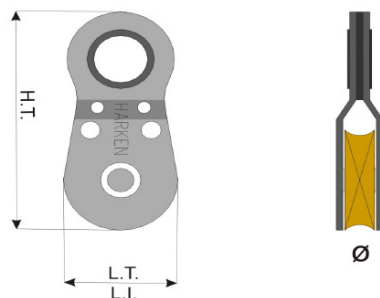

DATOS TÉCNICOS HILO

VELA

NOMBRE	SERAFIL
REFERENCIA	60
MATERIAL	POLYESTER
ACABADO	SILK
DENSIDAD LINEAL	NM 61 / 3 (DTEX 163 * 3)
RESISTENCIA A LA TRACCIÓN	3,000 CN
ALARGAMIENTO	17,00%

PROPIEDADES SERAFIL

SOLIDEZ A LA LUZ ARTIFICIAL	ISO 105 B02 > 5 - 6
SOLIDEZ AL SUDOR	ISO 105 E04 > 4
SOLIDEZ AL LAVADO	ISO 105 C04 > 3
SOLIDEZ AL FROTAMIENTO EN SECO	ISO 105 X12 > 4
SOLIDEZ AL LAVADO EN SECO	ISO 105 D01 > 3 - 4

TRATAMIENTO DE REPELENCIA AL AGUA	WR
-----------------------------------	----

BANDAS

NOMBRE	COATS BONDED C.F.P.
REFERENCIA	V138
MATERIAL	POLYESTER
ACABADO	SILK
RESISTENCIA A LA TRACCIÓN	9,5 KG
ALARGAMIENTO	19%

DATOS TÉCNICOS ELEVADORES

BANDAS

REFERENCIA	18
MATERIAL	POLYESTER
ANCHO	22 M/M
GRUESO	1,52 M/M
RESISTENCIA A LA TRACCIÓN	1,100DAN
ALARGAMIENTO	MAX. 15%
PESO	25 G* L.M.
COLOR	BLACK

INDICADOR COLOR

REFERENCIA	IC-G 1-2
MATERIAL	POLYESTER
ANCHO	70 M/M
GRUESO	0,80 M/M
RESISTENCIA ALA ROTURA	130 DN
ALARGAMIENTO	35 %
PESO	32 G * L.M.
COLOR	GREEN

CINTAS DE CARGA

REFERENCIA	LKI - 10
MATERIAL	NYLON
ANCHO	10 M/M
RESISTENCIA A LA TRACCIÓN	84 KG
ALARGAMIENTO	30 %
PESO	5,5 G/M
COLOR	WHITE

