

TECHNICAL SPECIFICATIONS

KOYOT 3



TECHNICAL DATA

KOYOT 3			22	24	26	28	31
CELLS	NUMBER		36	36	36	36	36
	CLOSED		8	8	8	8	8
	BOX		27	27	27	27	27
FLAT	AREA	m ²	22	24	26	28	31
	SPAN	m	10,44	10,90	11,35	11,77	12,39
	ASPECT RATIO		4,95	4,95	4,95	4,95	4,95
PROJECTED	AREA	m ²	19,04	20,77	22,50	24,23	26,83
	SPAN	m	8,48	8,86	9,22	9,56	10,06
	ASPECT RATIO		3,78	3,78	3,78	3,78	3,78
FLATTENING		%	13	13	13	13	13
CORD	MAXIMUM	m	2,55	2,67	2,78	2,88	3,03
	MINIMUM	m	0,66	0,69	0,72	0,75	0,79
	AVERAGE	m	2,11	2,20	2,29	2,38	2,50
LINES	TOTAL METERS	m	264	276	287	299	315
	HEIGHT	m	6,59	6,88	7,16	7,43	7,82
	NUMBER		206	206	206	206	206
	MAIN		2+1/3/4	2+1/3/4	2+1/3/4	2+1/3/4	2+1/3/4
RISERS	NUMBER	3	A+A'/B/C	A+A'/B/C	A+A'/B/C	A+A'/B/C	A+A'/B/C
	TRIMS		NO	NO	NO	NO	NO
	ACCELERATOR	m/m	110	110	110	110	110
	SPLIT A'S		YES	YES	YES	YES	YES
TOTAL WEIGHT	MINIMUM	kg	45	60	75	90	110
IN FLIGHT	MAXIMUM	kg	73	80	95	115	135
GLIDER WEIGHT		kg	4,25	4,54	4,93	5,11	5,40
CERTIFICATION		EN/LTF	A	A	A	A	A

MATERIALS TECHNICAL DATA

CANOPY	FABRIC CODE	SUPPLIER
UPPER SURFACE	9017 E25	PORCHER IND (FRANCE)
BOTTOM SURFACE	N-20-DMF 36	DOMINICO TEX CO
PROFILES	9017 E29	PORCHER IND (FRANCE)
DIAGONALS	9017 E29	PORCHER IND (FRANCE)
LOOPS	LKI - 10	KOLON IND. (KOREA)
REINFORCEMENT LOOPS	W-420	D-P (GERMANY)
TRAILING EDGE REINFORCEMENT	MYLAR	D-P (GERMANY)
RIB REINFORCEMENT	LTN-0.8 STICK	SPORTWARE CO.CHINA
THREAD	SERAFIL 60	AMAN (GERMANY)

SUSPENSION LINES	FABRIC CODE	SUPPLIER
UPPER CASCADES	TNL - 080	TEIJIM LIMITED (JAPAN)
MIDDLE CASCADES	TNL - 080	TEIJIM LIMITED (JAPAN)
MIDDLE CASCADES	TNL - 140	TEIJIM LIMITED (JAPAN)
MAIN	TNL - 220	TEIJIM LIMITED (JAPAN)
MAIN	TNL - 280	TEIJIM LIMITED (JAPAN)
MAIN BREAK	TNL - 280	TEIJIM LIMITED (JAPAN)
THREAD	SERAFIL 60	AMAN (GERMANY)

RISERS	FABRIC CODE	SUPPLIER
MATERIAL	WD103	COUSIN (FRANCE)
COLOR INDICATOR	210D	TECNI SANGLES (FRANCE)
THREAD	V138	COATS (ENGLAND)
MAILLONS	MRI4	ANSUNG PRECISION (KOREA)
PULLEYS	PY - 1304-2	ANSUNG PRECISION (KOREA)

SUSPENSION PLAN

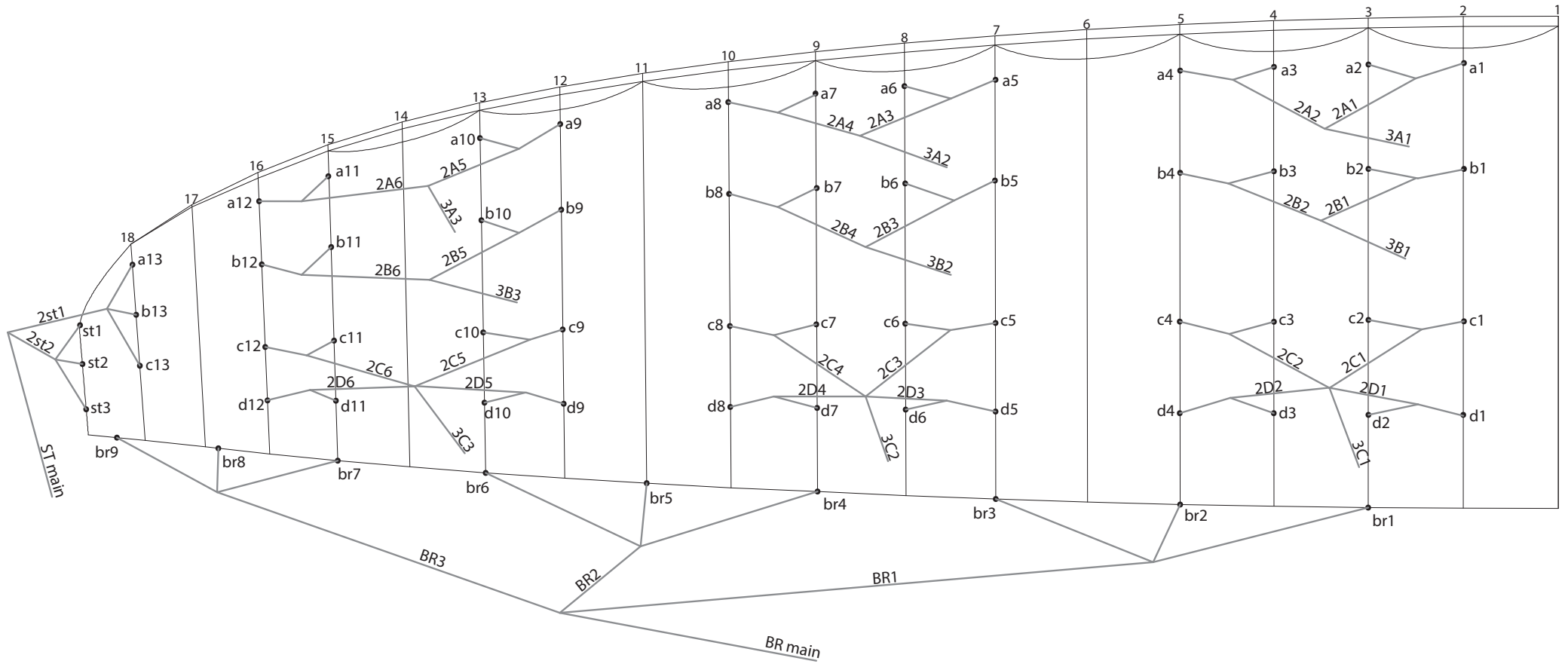

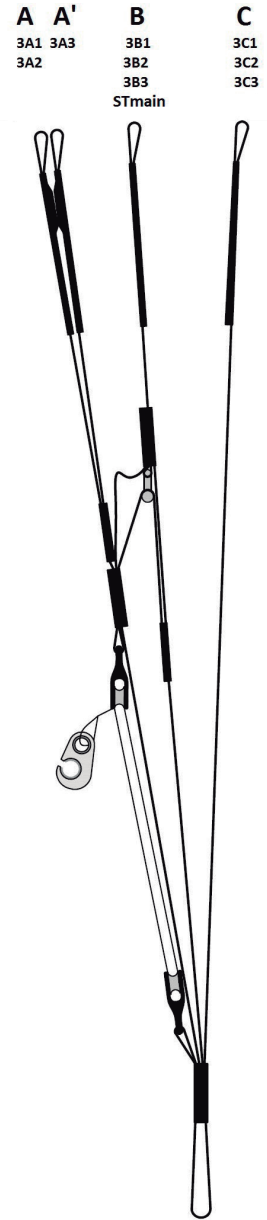

COLOURS TECHNICAL DATA

TROPICAL	SB1	LIMA	MAIN TOP	REF: NK375
	SB2	LIMA	MAIN BOTTOM	REF: NK375
	SB3	ORANGE	HORNS	REF: 744
	SB4	WHITE	PRINCIPAL SHADOW	REF: 001
	SB5	BLACK	VOLUME SHADOW	REF: 102



CITRUS	SB1	ORANGE	MAIN TOP	REF: 744
	SB2	ORANGE	MAIN BOTTOM	REF: 744
	SB3	LIMA	HORNS	REF: NK375
	SB4	BLACK	PRINCIPAL SHADOW	REF: 102
	SB5	RUBI	VOLUME SHADOW	REF: NK259



MARS	SB1	DRAGON RED	MAIN TOP	REF: 636
	SB2	DRAGON RED	MAIN BOTTOM	REF: 636
	SB3	ROYAL BLUE	HORNS	REF: 317
	SB4	WHITE	PRINCIPAL SHADOW	REF: 001
	SB5	BLACK	VOLUME SHADOW	REF: 102



BUTTERFLY	SB1	RUBI	MAIN TOP	REF: NK259
	SB2	RUBI	MAIN BOTTOM	REF: NK259
	SB3	ROYAL BLUE	HORNS	REF: 317
	SB4	WHITE	PRINCIPAL SHADOW	REF: 001
	SB5	BLACK	VOLUME SHADOW	REF: 102

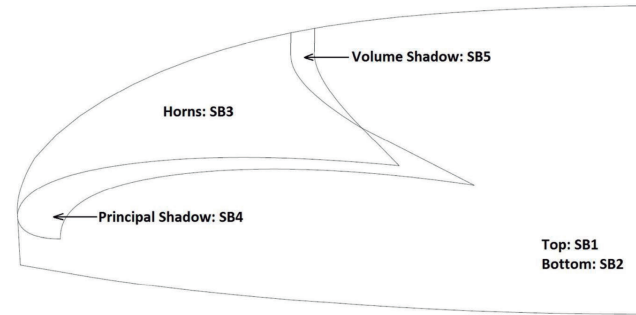

WING LOAD TECHNICAL DATA

KOYOT 3

22		24		26		28		31	
P.T.V.	kg/m ²	P.T.V.	kg/m ²	P.T.V.	kg/m ²	P.T.V.	kg/m ²	P.T.V.	kg/m ²
45	= 2,05	60	= 2,50	75	= 2,88	90	= 3,21	110	= 3,55
46	= 2,09	61	= 2,54	76	= 2,92	91	= 3,25	111	= 3,58
47	= 2,14	62	= 2,58	77	= 2,96	92	= 3,29	112	= 3,61
48	= 2,18	63	= 2,63	78	= 3,00	93	= 3,32	113	= 3,65
49	= 2,23	64	= 2,67	79	= 3,04	94	= 3,36	114	= 3,68
50	= 2,27	65	= 2,71	80	= 3,08	95	= 3,39	115	= 3,71
51	= 2,32	66	= 2,75	81	= 3,12	96	= 3,43	116	= 3,74
52	= 2,36	67	= 2,79	82	= 3,15	97	= 3,46	117	= 3,77
53	= 2,41	68	= 2,83	83	= 3,19	98	= 3,50	118	= 3,81
54	= 2,45	69	= 2,88	84	= 3,23	99	= 3,54	119	= 3,84
55	= 2,50	70	= 2,92	85	= 3,27	100	= 3,57	120	= 3,87
56	= 2,55	71	= 2,96	86	= 3,31	101	= 3,61	121	= 3,90
57	= 2,59	72	= 3,00	87	= 3,35	102	= 3,64	122	= 3,94
58	= 2,64	73	= 3,04	88	= 3,38	103	= 3,68	123	= 3,97
59	= 2,68	74	= 3,08	89	= 3,42	104	= 3,71	124	= 4,00
60	= 2,73	75	= 3,13	90	= 3,46	105	= 3,75	125	= 4,03
61	= 2,77	76	= 3,17	91	= 3,50	106	= 3,79	126	= 4,06
62	= 2,82	77	= 3,21	91	= 3,50	107	= 3,82	127	= 4,10
63	= 2,86	78	= 3,25	93	= 3,58	108	= 3,86	128	= 4,13
64	= 2,91	79	= 3,29	94	= 3,62	109	= 3,89	129	= 4,16
65	= 2,95	80	= 3,33	95	= 3,65	110	= 3,93	130	= 4,19
						111	= 3,96	131	= 4,23
						112	= 4,00	132	= 4,26
						113	= 4,04	133	= 4,29
						114	= 4,07	134	= 4,32
						115	= 4,11	135	= 4,35

LINES TECHNICAL DATA

KOYOT 3

22

REF.	CODE	m/m	REF.	CODE	m/m	REF.	CODE	m/m	REF.	CODE	m/m	REF.	CODE	m/m
A			B			C			D			BRAKE		
a1	TNL-080-GREEN	762	b1	TNL-080-BLU	758	c1	TNL-080-BLU	851	d1	TNL-080-BLU	500	br1	TNL-080-RED	2.212
a2	TNL-080-GREEN	719	b2	TNL-080-BLU	711	c2	TNL-080-BLU	789	d2	TNL-080-BLU	442	br2	TNL-080-RED	1.975
a3	TNL-080-GREEN	709	b3	TNL-080-BLU	708	c3	TNL-080-BLU	788	d3	TNL-080-BLU	847	br3	TNL-080-RED	1.926
a4	TNL-080-GREEN	753	b4	TNL-080-BLU	747	c4	TNL-080-BLU	820	d4	TNL-080-BLU	874	br4	TNL-080-RED	1.910
a5	TNL-080-GREEN	731	b5	TNL-080-BLU	724	c5	TNL-080-BLU	757	d5	TNL-080-BLU	476	br5	TNL-080-RED	1.798
a6	TNL-080-GREEN	682	b6	TNL-080-BLU	674	c6	TNL-080-BLU	698	d6	TNL-080-BLU	417	br6	TNL-080-RED	1.810
a7	TNL-080-GREEN	678	b7	TNL-080-BLU	670	c7	TNL-080-BLU	693	d7	TNL-080-BLU	423	br7	TNL-080-RED	1.073
a8	TNL-080-GREEN	702	b8	TNL-080-BLU	693	c8	TNL-080-BLU	725	d8	TNL-080-BLU	447	br8	TNL-080-RED	934
a9	TNL-080-GREEN	660	b9	TNL-080-BLU	644	c9	TNL-080-BLU	638	d9	TNL-080-BLU	419	br9	TNL-080-RED	778
a10	TNL-080-GREEN	601	b10	TNL-080-BLU	588	c10	TNL-080-BLU	576	d10	TNL-080-BLU	357			
a11	TNL-080-GREEN	618	b11	TNL-080-BLU	571	c11	TNL-080-BLU	545	d11	TNL-080-BLU	352			
a12	TNL-080-GREEN	592	b12	TNL-080-BLU	549	c12	TNL-080-BLU	520	d12	TNL-080-BLU	323			
a13	TNL-080-RED	1.193	b13	TNL-080-RED	1.161	c13	TNL-080-RED	1.205						
st1	TNL-080-RED	941	st2	TNL-080-RED	952	st3	TNL-080-RED	1.016						
2A1	TNL-140-GREEN	1.060	2B1	TNL-140-BLU	1.067	2C1	TNL-080-BLU	804	2D1	TNL-080-BLU	1.282	BR1	TNL-140-RED	2.880
2A2	TNL-140-GREEN	1.049	2B2	TNL-140-BLU	1.048	2C2	TNL-080-BLU	789	2D2	TNL-080-BLU	845	BR2	TNL-140-RED	2.804
2A3	TNL-140-GREEN	1.075	2B3	TNL-140-BLU	1.063	2C3	TNL-080-BLU	788	2D3	TNL-080-BLU	1.190	BR3	TNL-140-RED	3.468
2A4	TNL-140-GREEN	1.066	2B4	TNL-140-BLU	1.054	2C4	TNL-080-BLU	778	2D4	TNL-080-BLU	1.164			
2A5	TNL-140-GREEN	1.357	2B5	TNL-140-BLU	1.280	2C5	TNL-080-BLU	1.141	2D5	TNL-080-BLU	1.436			
2A6	TNL-140-GREEN	1.260	2B6	TNL-140-BLU	1.225	2C6	TNL-080-BLU	1.095	2D6	TNL-080-BLU	1.342			
2st1	TNL-80-RED	381	2st2	TNL-80-RED	518									
3A1	TNL-280-GREEN	4.152	3B1	TNL-280-BLU	4.087	3C1	TNL-280-BLU	4.360				Brmain	TNL-280-RED	1.702
3A2	TNL-280-GREEN	4.100	3B2	TNL-280-BLU	4.065	3C2	TNL-280-BLU	4.401					Knot mark:	1.502
3A3	TNL-220-GREEN	3.824	3B3	TNL-220-BLU	3.865	3C3	TNL-220-BLU	4.074						
						STmain	TNL-140-RED	3.875						

LINES TECHNICAL DATA

KOYOT 3

24

REF.	CODE	m/m	REF.	CODE	m/m	REF.	CODE	m/m	REF.	CODE	m/m	REF.	CODE	m/m
A			B			C			D			BRAKE		
a1	TNL-080-GREEN	804	b1	TNL-080-BLU	800	c1	TNL-080-BLU	898	d1	TNL-080-BLU	528	br1	TNL-080-RED	2.335
a2	TNL-080-GREEN	760	b2	TNL-080-BLU	753	c2	TNL-080-BLU	833	d2	TNL-080-BLU	468	br2	TNL-080-RED	2.089
a3	TNL-080-GREEN	748	b3	TNL-080-BLU	747	c3	TNL-080-BLU	833	d3	TNL-080-BLU	894	br3	TNL-080-RED	2.042
a4	TNL-080-GREEN	796	b4	TNL-080-BLU	789	c4	TNL-080-BLU	868	d4	TNL-080-BLU	925	br4	TNL-080-RED	2.017
a5	TNL-080-GREEN	772	b5	TNL-080-BLU	765	c5	TNL-080-BLU	800	d5	TNL-080-BLU	503	br5	TNL-080-RED	1.900
a6	TNL-080-GREEN	721	b6	TNL-080-BLU	713	c6	TNL-080-BLU	738	d6	TNL-080-BLU	441	br6	TNL-080-RED	1.914
a7	TNL-080-GREEN	716	b7	TNL-080-BLU	707	c7	TNL-080-BLU	732	d7	TNL-080-BLU	447	br7	TNL-080-RED	1.296
a8	TNL-080-GREEN	742	b8	TNL-080-BLU	732	c8	TNL-080-BLU	766	d8	TNL-080-BLU	473	br8	TNL-080-RED	1.155
a9	TNL-080-GREEN	697	b9	TNL-080-BLU	681	c9	TNL-080-BLU	674	d9	TNL-080-BLU	442	br9	TNL-080-RED	978
a10	TNL-080-GREEN	635	b10	TNL-080-BLU	621	c10	TNL-080-BLU	609	d10	TNL-080-BLU	377			
a11	TNL-080-GREEN	653	b11	TNL-080-BLU	603	c11	TNL-080-BLU	575	d11	TNL-080-BLU	372			
a12	TNL-080-GREEN	626	b12	TNL-080-BLU	580	c12	TNL-080-BLU	550	d12	TNL-080-BLU	341			
a13	TNL-080-RED	1.261	b13	TNL-080-RED	1.227	c13	TNL-080-RED	1.273						
st1	TNL-080-RED	994	st2	TNL-080-RED	1.006	st3	TNL-080-RED	1.074						
2A1	TNL-140-GREEN	1.119	2B1	TNL-140-BLU	1.126	2C1	TNL-080-BLU	849	2D1	TNL-080-BLU	1.352	BR1	TNL-140-RED	3.106
2A2	TNL-140-GREEN	1.110	2B2	TNL-140-BLU	1.110	2C2	TNL-080-BLU	834	2D2	TNL-080-BLU	894	BR2	TNL-140-RED	3.038
2A3	TNL-140-GREEN	1.135	2B3	TNL-140-BLU	1.122	2C3	TNL-080-BLU	831	2D3	TNL-080-BLU	1.258	BR3	TNL-140-RED	3.571
2A4	TNL-140-GREEN	1.127	2B4	TNL-140-BLU	1.115	2C4	TNL-080-BLU	823	2D4	TNL-080-BLU	1.232			
2A5	TNL-140-GREEN	1.434	2B5	TNL-140-BLU	1.352	2C5	TNL-080-BLU	1.205	2D5	TNL-080-BLU	1.516			
2A6	TNL-140-GREEN	1.331	2B6	TNL-140-BLU	1.295	2C6	TNL-080-BLU	1.158	2D6	TNL-080-BLU	1.417			
2st1	TNL-80-RED	402	2st2	TNL-80-RED	547									
3A1	TNL-280-GREEN	4.415	3B1	TNL-280-BLU	4.342	3C1	TNL-280-BLU	4.633				Brmain	TNL-280-RED	1.732
3A2	TNL-280-GREEN	4.365	3B2	TNL-280-BLU	4.328	3C2	TNL-280-BLU	4.684					Knot mark:	1.532
3A3	TNL-220-GREEN	4.076	3B3	TNL-220-BLU	4.120	3C3	TNL-220-BLU	4.339						
						STmain	TNL-140-RED	4.132						

LINES TECHNICAL DATA

KOYOT 3

26

REF.	CODE	m/m	REF.	CODE	m/m	REF.	CODE	m/m	REF.	CODE	m/m	REF.	CODE	m/m
A			B			C			D			BRAKE		
a1	TNL-080-GREEN	837	b1	TNL-080-BLU	833	c1	TNL-080-BLU	934	d1	TNL-080-BLU	549	br1	TNL-080-RED	2.431
a2	TNL-080-GREEN	792	b2	TNL-080-BLU	784	c2	TNL-080-BLU	867	d2	TNL-080-BLU	488	br2	TNL-080-RED	2.173
a3	TNL-080-GREEN	778	b3	TNL-080-BLU	776	c3	TNL-080-BLU	867	d3	TNL-080-BLU	931	br3	TNL-080-RED	2.122
a4	TNL-080-GREEN	829	b4	TNL-080-BLU	822	c4	TNL-080-BLU	904	d4	TNL-080-BLU	963	br4	TNL-080-RED	2.098
a5	TNL-080-GREEN	803	b5	TNL-080-BLU	796	c5	TNL-080-BLU	833	d5	TNL-080-BLU	523	br5	TNL-080-RED	1.978
a6	TNL-080-GREEN	751	b6	TNL-080-BLU	743	c6	TNL-080-BLU	768	d6	TNL-080-BLU	460	br6	TNL-080-RED	1.994
a7	TNL-080-GREEN	745	b7	TNL-080-BLU	736	c7	TNL-080-BLU	762	d7	TNL-080-BLU	464	br7	TNL-080-RED	1.180
a8	TNL-080-GREEN	772	b8	TNL-080-BLU	762	c8	TNL-080-BLU	797	d8	TNL-080-BLU	492	br8	TNL-080-RED	1.029
a9	TNL-080-GREEN	726	b9	TNL-080-BLU	708	c9	TNL-080-BLU	701	d9	TNL-080-BLU	461	br9	TNL-080-RED	859
a10	TNL-080-GREEN	661	b10	TNL-080-BLU	647	c10	TNL-080-BLU	634	d10	TNL-080-BLU	393			
a11	TNL-080-GREEN	679	b11	TNL-080-BLU	627	c11	TNL-080-BLU	599	d11	TNL-080-BLU	387			
a12	TNL-080-GREEN	652	b12	TNL-080-BLU	604	c12	TNL-080-BLU	572	d12	TNL-080-BLU	355			
a13	TNL-080-RED	1.312	b13	TNL-080-RED	1.277	c13	TNL-080-RED	1.325						
st1	TNL-080-RED	1.035	st2	TNL-080-RED	1.047	st3	TNL-080-RED	1.118						
2A1	TNL-140-GREEN	1.163	2B1	TNL-140-BLU	1.171	2C1	TNL-080-BLU	883	2D1	TNL-080-BLU	1.406	BR1	TNL-140-RED	3.161
2A2	TNL-140-GREEN	1.157	2B2	TNL-140-BLU	1.157	2C2	TNL-080-BLU	868	2D2	TNL-080-BLU	930	BR2	TNL-140-RED	3.087
2A3	TNL-140-GREEN	1.181	2B3	TNL-140-BLU	1.167	2C3	TNL-080-BLU	864	2D3	TNL-080-BLU	1.308	BR3	TNL-140-RED	3.823
2A4	TNL-140-GREEN	1.173	2B4	TNL-140-BLU	1.161	2C4	TNL-080-BLU	857	2D4	TNL-080-BLU	1.283			
2A5	TNL-140-GREEN	1.492	2B5	TNL-140-BLU	1.406	2C5	TNL-080-BLU	1.254	2D5	TNL-080-BLU	1.578			
2A6	TNL-140-GREEN	1.386	2B6	TNL-140-BLU	1.349	2C6	TNL-080-BLU	1.205	2D6	TNL-080-BLU	1.476			
2st1	TNL-80-RED	418	2st2	TNL-80-RED	569									
3A1	TNL-280-GREEN	4.616	3B1	TNL-280-BLU	4.540	3C1	TNL-280-BLU	4.844				Brmain	TNL-280-RED	1.910
3A2	TNL-280-GREEN	4.568	3B2	TNL-280-BLU	4.529	3C2	TNL-280-BLU	4.899					Knot mark:	1.710
3A3	TNL-220-GREEN	4.269	3B3	TNL-220-BLU	4.315	3C3	TNL-220-BLU	4.543						
						STmain	TNL-140-RED	4.329						

LINES TECHNICAL DATA

KOYOT 3			28											
REF.	CODE	m/m	REF.	CODE	m/m	REF.	CODE	m/m	REF.	CODE	m/m	REF.	CODE	m/m
A			B			C			D			BRAKE		
a1	TNL-080-GREEN	868	b1	TNL-080-BLU	864	c1	TNL-080-BLU	968	d1	TNL-080-BLU	570	br1	TNL-080-RED	2.521
a2	TNL-080-GREEN	823	b2	TNL-080-BLU	815	c2	TNL-080-BLU	900	d2	TNL-080-BLU	507	br2	TNL-080-RED	2.258
a3	TNL-080-GREEN	807	b3	TNL-080-BLU	805	c3	TNL-080-BLU	899	d3	TNL-080-BLU	966	br3	TNL-080-RED	2.209
a4	TNL-080-GREEN	860	b4	TNL-080-BLU	853	c4	TNL-080-BLU	939	d4	TNL-080-BLU	1.000	br4	TNL-080-RED	2.178
a5	TNL-080-GREEN	834	b5	TNL-080-BLU	826	c5	TNL-080-BLU	864	d5	TNL-080-BLU	543	br5	TNL-080-RED	2.054
a6	TNL-080-GREEN	779	b6	TNL-080-BLU	771	c6	TNL-080-BLU	798	d6	TNL-080-BLU	477	br6	TNL-080-RED	2.070
a7	TNL-080-GREEN	773	b7	TNL-080-BLU	763	c7	TNL-080-BLU	790	d7	TNL-080-BLU	482	br7	TNL-080-RED	1.400
a8	TNL-080-GREEN	801	b8	TNL-080-BLU	791	c8	TNL-080-BLU	827	d8	TNL-080-BLU	511	br8	TNL-080-RED	1.249
a9	TNL-080-GREEN	753	b9	TNL-080-BLU	735	c9	TNL-080-BLU	728	d9	TNL-080-BLU	478	br9	TNL-080-RED	1.060
a10	TNL-080-GREEN	686	b10	TNL-080-BLU	671	c10	TNL-080-BLU	658	d10	TNL-080-BLU	408			
a11	TNL-080-GREEN	705	b11	TNL-080-BLU	651	c11	TNL-080-BLU	621	d11	TNL-080-BLU	402			
a12	TNL-080-GREEN	676	b12	TNL-080-BLU	627	c12	TNL-080-BLU	594	d12	TNL-080-BLU	369			
a13	TNL-080-RED	1.362	b13	TNL-080-RED	1.325	c13	TNL-080-RED	1.375						
st1	TNL-080-RED	1.074	st2	TNL-080-RED	1.087	st3	TNL-080-RED	1.160						
2A1	TNL-140-GREEN	1.206	2B1	TNL-140-BLU	1.214	2C1	TNL-080-BLU	916	2D1	TNL-080-BLU	1.458	BR1	TNL-140-RED	3.351
2A2	TNL-140-GREEN	1.202	2B2	TNL-140-BLU	1.202	2C2	TNL-080-BLU	901	2D2	TNL-080-BLU	966	BR2	TNL-140-RED	3.284
2A3	TNL-140-GREEN	1.225	2B3	TNL-140-BLU	1.211	2C3	TNL-080-BLU	896	2D3	TNL-080-BLU	1.356	BR3	TNL-140-RED	3.865
2A4	TNL-140-GREEN	1.218	2B4	TNL-140-BLU	1.206	2C4	TNL-080-BLU	890	2D4	TNL-080-BLU	1.331			
2A5	TNL-140-GREEN	1.548	2B5	TNL-140-BLU	1.459	2C5	TNL-080-BLU	1.301	2D5	TNL-080-BLU	1.632			
2A6	TNL-140-GREEN	1.439	2B6	TNL-140-BLU	1.400	2C6	TNL-080-BLU	1.251	2D6	TNL-080-BLU	1.532			
2st1	TNL-80-RED	434	2st2	TNL-80-RED	591									
3A1	TNL-280-GREEN	4.809	3B1	TNL-280-BLU	4.729	3C1	TNL-280-BLU	5.047				Brmain	TNL-280-RED	1.890
3A2	TNL-280-GREEN	4.762	3B2	TNL-280-BLU	4.722	3C2	TNL-280-BLU	5.107					Knot mark:	1.690
3A3	TNL-220-GREEN	4.454	3B3	TNL-220-BLU	4.502	3C3	TNL-220-BLU	4.739						
						STmain	TNL-140-RED	4.517						

LINES TECHNICAL DATA

KOYOT 3

31

REF.	CODE	m/m	REF.	CODE	m/m	REF.	CODE	m/m	REF.	CODE	m/m	REF.	CODE	m/m
A			B			C			D			BRAKE		
a1	TNL-080-GREEN	913	b1	TNL-080-BLU	909	c1	TNL-080-BLU	1.017	d1	TNL-080-BLU	599	br1	TNL-080-RED	2.653
a2	TNL-080-GREEN	867	b2	TNL-080-BLU	859	c2	TNL-080-BLU	946	d2	TNL-080-BLU	534	br2	TNL-080-RED	2.374
a3	TNL-080-GREEN	848	b3	TNL-080-BLU	846	c3	TNL-080-BLU	946	d3	TNL-080-BLU	1.016	br3	TNL-080-RED	2.320
a4	TNL-080-GREEN	905	b4	TNL-080-BLU	898	c4	TNL-080-BLU	989	d4	TNL-080-BLU	1.053	br4	TNL-080-RED	2.289
a5	TNL-080-GREEN	877	b5	TNL-080-BLU	869	c5	TNL-080-BLU	909	d5	TNL-080-BLU	571	br5	TNL-080-RED	2.161
a6	TNL-080-GREEN	821	b6	TNL-080-BLU	812	c6	TNL-080-BLU	840	d6	TNL-080-BLU	503	br6	TNL-080-RED	2.180
a7	TNL-080-GREEN	813	b7	TNL-080-BLU	802	c7	TNL-080-BLU	831	d7	TNL-080-BLU	507	br7	TNL-080-RED	1.288
a8	TNL-080-GREEN	844	b8	TNL-080-BLU	833	c8	TNL-080-BLU	871	d8	TNL-080-BLU	538	br8	TNL-080-RED	1.125
a9	TNL-080-GREEN	793	b9	TNL-080-BLU	773	c9	TNL-080-BLU	766	d9	TNL-080-BLU	503	br9	TNL-080-RED	901
a10	TNL-080-GREEN	722	b10	TNL-080-BLU	707	c10	TNL-080-BLU	693	d10	TNL-080-BLU	429			
a11	TNL-080-GREEN	742	b11	TNL-080-BLU	685	c11	TNL-080-BLU	654	d11	TNL-080-BLU	423			
a12	TNL-080-GREEN	712	b12	TNL-080-BLU	660	c12	TNL-080-BLU	625	d12	TNL-080-BLU	388			
a13	TNL-080-RED	1.433	b13	TNL-080-RED	1.395	c13	TNL-080-RED	1.447						
st1	TNL-080-RED	1.130	st2	TNL-080-RED	1.143	st3	TNL-080-RED	1.220						
2A1	TNL-140-GREEN	1.268	2B1	TNL-140-BLU	1.276	2C1	TNL-080-BLU	963	2D1	TNL-080-BLU	1.533	BR1	TNL-140-RED	3.447
2A2	TNL-140-GREEN	1.267	2B2	TNL-140-BLU	1.268	2C2	TNL-080-BLU	948	2D2	TNL-080-BLU	1.016	BR2	TNL-140-RED	3.374
2A3	TNL-140-GREEN	1.288	2B3	TNL-140-BLU	1.273	2C3	TNL-080-BLU	942	2D3	TNL-080-BLU	1.425	BR3	TNL-140-RED	4.183
2A4	TNL-140-GREEN	1.283	2B4	TNL-140-BLU	1.270	2C4	TNL-080-BLU	937	2D4	TNL-080-BLU	1.401			
2A5	TNL-140-GREEN	1.629	2B5	TNL-140-BLU	1.535	2C5	TNL-080-BLU	1.369	2D5	TNL-080-BLU	1.722			
2A6	TNL-140-GREEN	1.514	2B6	TNL-140-BLU	1.474	2C6	TNL-080-BLU	1.317	2D6	TNL-080-BLU	1.612			
2st1	TNL-80-RED	457	2st2	TNL-80-RED	621									
3A1	TNL-280-GREEN	5.066	3B1	TNL-280-BLU	4.987	3C1	TNL-280-BLU	5.323				Brmain	TNL-280-RED	2.090
3A2	TNL-280-GREEN	5.042	3B2	TNL-280-BLU	5.000	3C2	TNL-280-BLU	5.405					Knot mark:	1.890
3A3	TNL-220-GREEN	4.719	3B3	TNL-220-BLU	4.771	3C3	TNL-220-BLU	5.021						
						STmain	TNL-140-RED	4.789						

NIVIUK KOYOT 3 22

LINES HEIGHT m/m

	A	B	C	D	br
1	5.964	5.902	6.005	6.132	6.582
2	5.921	5.855	5.943	6.074	6.345
3	5.900	5.833	5.927	6.042	6.296
4	5.944	5.872	5.959	6.069	6.204
5	5.896	5.842	5.936	6.057	6.092
6	5.847	5.792	5.877	5.998	6.104
7	5.834	5.779	5.862	5.978	6.031
8	5.858	5.802	5.894	6.002	5.892
9	5.831	5.779	5.843	5.919	5.736
10	5.772	5.723	5.781	5.857	
11	5.692	5.651	5.704	5.758	
12	5.666	5.629	5.679	5.729	
13	5.439	5.407	5.451		
stb	5.329	5.340	5.405		

RISERS LENGTH m/m

	A	A'	B	C	
	470	470	470	470	STANDARD
	360	360	390	470	ACCELERATED

NIVIUK KOYOT 3 24

LINES HEIGHT m/m

	A	B	C	D	br
1	6.328	6.258	6.370	6.503	6.961
2	6.284	6.211	6.305	6.443	6.715
3	6.263	6.189	6.290	6.411	6.668
4	6.311	6.231	6.325	6.442	6.575
5	6.262	6.205	6.305	6.435	6.458
6	6.211	6.153	6.243	6.373	6.472
7	6.198	6.140	6.229	6.353	6.387
8	6.224	6.165	6.263	6.379	6.246
9	6.197	6.143	6.208	6.287	6.069
10	6.135	6.083	6.143	6.222	
11	6.050	6.008	6.062	6.118	
12	6.023	5.985	6.037	6.087	
13	5.785	5.751	5.797		
stb	5.669	5.680	5.748		

RISERS LENGTH m/m

	A	A'	B	C	
	470	470	470	470	STANDARD
	360	360	390	470	ACCELERATED

LINES HEIGHT m/m

	A	B	C	D	br
1	6.606	6.534	6.651	6.789	7.290
2	6.561	6.485	6.584	6.728	7.032
3	6.541	6.463	6.569	6.695	6.981
4	6.592	6.509	6.606	6.727	6.883
5	6.542	6.482	6.586	6.720	6.763
6	6.490	6.429	6.521	6.657	6.779
7	6.476	6.416	6.508	6.636	6.701
8	6.503	6.442	6.543	6.664	6.550
9	6.477	6.419	6.488	6.572	6.380
10	6.412	6.358	6.421	6.504	
11	6.324	6.281	6.337	6.396	
12	6.297	6.258	6.310	6.364	
13	6.049	6.014	6.062		
stb	5.928	5.940	6.011		

RISERS LENGTH m/m

	A	A'	B	C	
	470	470	470	470	STANDARD
	360	360	390	470	ACCELERATED

LINES HEIGHT m/m

	A	B	C	D	br
1	6.873	6.797	6.921	7.065	7.550
2	6.828	6.748	6.853	7.002	7.287
3	6.808	6.726	6.837	6.969	7.238
4	6.861	6.774	6.877	7.003	7.140
5	6.811	6.749	6.857	6.996	7.016
6	6.756	6.694	6.791	6.930	7.032
7	6.743	6.681	6.777	6.910	6.943
8	6.771	6.709	6.814	6.939	6.792
9	6.745	6.686	6.758	6.839	6.603
10	6.678	6.622	6.688	6.769	
11	6.588	6.543	6.601	6.663	
12	6.559	6.519	6.574	6.630	
13	6.303	6.266	6.316		
stb	6.177	6.190	6.263		

RISERS LENGTH m/m

	A	A'	B	C	
	470	470	470	470	STANDARD
	360	360	390	470	ACCELERATED

LINES HEIGHT m/m

	A	B	C	D	br
1	7.237	7.162	7.293	7.445	7.978
2	7.191	7.112	7.222	7.380	7.699
3	7.171	7.091	7.207	7.345	7.645
4	7.228	7.143	7.250	7.382	7.541
5	7.197	7.132	7.246	7.391	7.413
6	7.141	7.075	7.177	7.323	7.432
7	7.128	7.062	7.163	7.303	7.349
8	7.159	7.093	7.203	7.334	7.186
9	7.131	7.069	7.146	7.236	6.962
10	7.060	7.003	7.073	7.162	
11	6.965	6.920	6.982	7.046	
12	6.935	6.895	6.953	7.011	
13	6.669	6.631	6.683		
stb	6.535	6.548	6.625		

RISERS LENGTH m/m

	A	A'	B	C	
	470	470	470	470	STANDARD
	360	360	390	470	ACCELERATED

SUSPENSION TECHNICAL DATA
KOYOT 3

MATERIAL CODE		TNL	TNL	TNL	TNL
STRENGTH CODE		080	140	220	280
DIAMETER m/m	Ø	1,1	1,4	1,6	1,8
CORE MATERIAL		TECHNORA	TECHNORA	TECHNORA	TECHNORA
SLEEVE MATERIAL		POLYESTER	POLYESTER	POLYESTER	POLYESTER
WEIGHT g/m	TOTAL	1,1	1,2	2,35	2,7
	CORE	0,45	0,76	1,22	1,55
	SLEEVE	0,65	1,2	1,13	1,15
BREAKING STRENGTH	MINIMUM	80	140	220	280
	MAXIMUM	92	160	250	320
STRENGTH AFTER					
5.000 BENDING CYCLES	TEST EN	36,7	76,1	114,2	134,7
ELONGATION AT	5 dan en %	0,3	0,2	0,2	0,2
	10 dan en %	0,5	0,3	0,3	0,3
	15 dan en %	0,7	0,5	0,5	0,4
	20 dan en %	1	0,6	0,6	0,4
	25 dan en %	1,3	0,8	0,7	0,5
	30 dan en %	2,3	1,5	1,2	0,9
	75 dan en %	2,8	2,3	1,8	1,3
	100 dan en %		2,7	2,2	1,7
	125 dan en %		3,2	2,7	2
	150 dan en %			3	2,3
	175 dan en %			3,3	2,7
	200 dan en %			3,8	2,8
ELONGATION MAX. BREAKING STRENGTH %		3	3,4	4	4,1

MAILLON & PULLEY TECHNICAL DATA

DESCRIPTION

MAILLON	DELTA
CODE	MRI4
MATERIAL	STAINLESS STEEL
SIZE	4,3 m/m
WEIGHT	12 g/piece

TECHNICAL SPECIFICATIONS

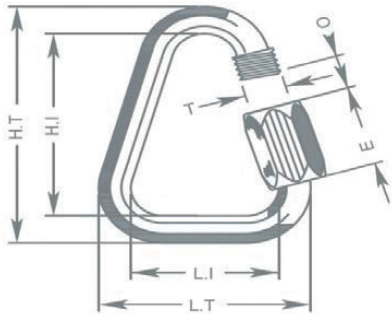

DIMENSIONS	m/m
L.T.	28
L.I.	20
H.T.	38
H.I.	30
O	4
E	11
T	4
LOAD	kg
WORKING LIMIT	150
BREAKING	750

MATERIAL

AISI 304 STAINLESS STEEL	STANDARD
--------------------------	----------

CLOSING APPLIED BY MANUAL & ENTIRE SCREWING OF THE NUT TO GUARANTEE THE HIGHEST SAFETY (NO THREAD SHOULD BE OBVIOUS)

SYSTEMATIC CONTROL OF MAILLON QUICK-LINKS BEFORE EVERY FLIGHT

THREAD TECHNICAL DATA**SAIL MAKING**

NAME	SERAFIL
N° OF REFERENCE	60
MATERIAL	POLYESTER
TYPE OF FINISH	SILK
LINEAR DENSITY	NM 61 / 3 (DTEX 163 * 3)
BREAKING STRENGTH	3,000 CN
ELONGATION	17,00%

SERAFIL PROPERTIES

SOLIDITY ARTIFICIAL LIGTH	ISO 105 B02 > 5 - 6
SOLIDITY SWEAT	ISO 105 E04 > 4
SOLIDITY WASHING	ISO 105 C04 > 3
SOLIDITY GRAZE IN DRY	ISO 105 X12 > 4
SOLIDITY WASHING IN DRY	ISO 105 D01 > 3 - 4

TREATMENT WATER REPELLENT	WR
---------------------------	----

RISERS MAKING

NAME	COATS BONDED C.F.P.
N° OF REFERENCE	V138
MATERIAL	POLYESTER
TYPE OF FINISH	SILK
BREAKING STRENGTH	9,5 kg
ELONGATION	19%

RISERS TECHNICAL DATA**RISERS**

N° OF REFERENCE	WD103
MATERIAL	POLYESTER & TECHNORA
WIDTH	19 m/m
THICKNESS	1,6 m/m
BREAKING STRENGTH	850 kg
ELONGATION	MAX. 12%
WEIGHT	23 g/m
COLOUR	BLACK

COLOUR INDICATOR

N° OF REFERENCE	IC-G 1-2
MATERIAL	POLYESTER
WIDTH	70 m/m
THICKNESS	0,80 m/m
BREAKING STRENGTH	130 DN
ELONGATION	35 %
WEIGHT	32 G * L.M.
COLOUR	GREEN

LOOPS

N° OF REFERENCE	LKI - 10
MATERIAL	NYLON
WIDTH	10 m/m
BREAKING STRENGTH	84 kg
ELONGATION	30 %
WEIGHT	5,5 g/m
COLOUR	WHITE

