

# ESPECIFICACIONES TÉCNICAS



KOYOT

**DATOS TÉCNICOS**

<b>KOYOT</b>			<b>22</b>	<b>24</b>	<b>26</b>	<b>28</b>	<b>31</b>
ALVÉOLOS	NÚMERO		37	37	37	37	37
	CERRADOS		4	4	4	4	4
	CAJONES		31	31	31	31	31
EN PLANTA	ÁREA	M2	21,5	24	26	28	31
	ENVERGADURA	M	10,26	10,84	11,27	11,71	12,32
	ALARGAMIENTO		4,9	4,9	4,9	4,9	4,9
PROYECTADO	ÁREA	M2	18,31	20,41	22,58	23,76	26,27
	ENVERGADURA	M	8,1	8,54	9,13	9,2	9,66
	ALARGAMIENTO		3,69	3,69	3,69	3,69	3,69
BÓVEDA		%	15	15	15	15	15
CUERDA	MÁXIMA	M	2,55	2,69	2,8	2,9	3,06
	MÍNIMA	M	0,59	0,63	0,65	0,67	0,71
	MEDIA		2,09	2,21	2,3	2,39	2,51
SUSPENTES	METROS TOTALES	M	324	342	359	369	389
	ALTURA	M	6,06	6,4	6,65	6,91	7,27
	NÚMERO		244	244	244	244	244
	PRINCIPALES		3/4/3/3	3/4/3/3	3/4/3/3	3/4/3/3	3/4/3/3
ELEVADORES	BANDAS	4	A/B/C/D	A/B/C/D	A/B/C/D	A/B/C/D	A/B/C/D
	TRIMS		NO	NO	NO	NO	NO
CARGA TOTAL	MÍNIMO	KG	45	60	75	90	110
EN VUELO	MÁXIMO	KG	65	80	95	115	135
PESO DEL ALA		KG	5,05	5,3	5,6	5,9	6,3
HOMOLOGACIÓN EN		B	B	B	B	A	
	LTF		1	1	1	1	1

**DATOS TÉCNICOS MATERIALES**

<b>VELA</b>	<b>REFERENCIA</b>	<b>FABRICANTE</b>
EXTRADÓS	SKYTEX 45 9092 E85A	NCV (FRANCE)
INTRADÓS	SKYTEX 40 9017 E38A	NCV (FRANCE)
PERFILES	3RS FM	DOMINICO
DIAGONALES	3RS FM	DOMINICO
CINTA DE CARGA	LKI - 10	KOLON INDUSTRIAL (KOREA)
REFUERZOS CARGA PERFIL	W-420	D-P (GERMANY)
RIBETE	MYLAR 25 M/M	D-P (GERMANY)
REFUERZOS PERFIL	W-420	D-P (GERMANY)
HILO	SERAFIL 40	AMAN (GERMANY)
<b>SUSPENTES</b>	<b>REFERENCIA</b>	<b>FABRICANTE</b>
CONO ALTO	TNL - 080	TEIJIN LIMITED (JAPAN)
CONO MEDIO	TNL - 080	TEIJIN LIMITED (JAPAN)
CONO MEDIO	TNL - 140	TEIJIN LIMITED (JAPAN)
PRINCIPAL	TNL - 140	TEIJIN LIMITED (JAPAN)
PRINCIPAL	TNL - 220	TEIJIN LIMITED (JAPAN)
PRINCIPAL	TNL - 280	TEIJIN LIMITED (JAPAN)
PRINCIPAL FRENO	TNL - 400	TEIJIN LIMITED (JAPAN)
HILO	SERAFIL 60	AMAN (GERMANY)
<b>ELEVADORES</b>	<b>REFERENCIA</b>	<b>FABRICANTE</b>
BANDAS	G-R 22	TECHNI SANGLES (FRANCE)
INDICADOR DE COLOR	PAD	TECHNI SANGLES (FRANCE)
HILO	N/F-66	YOUNG CHANG T&C LTD
MAILLONES	MRI4	ANSUNG PRECISION (KOREA)
POLEAS	PY-1304 - 2	ANSUNG PRECISION (KOREA)

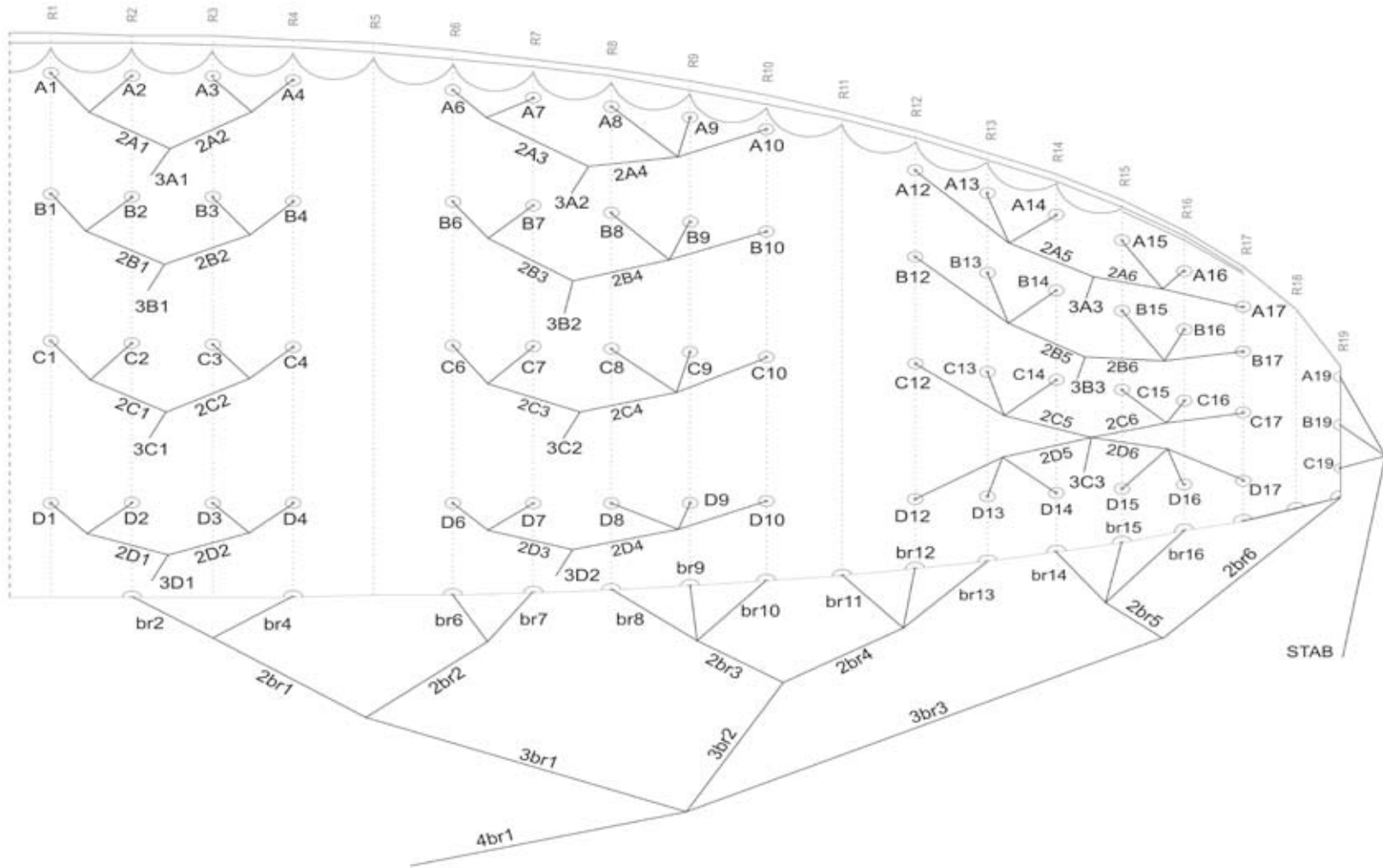

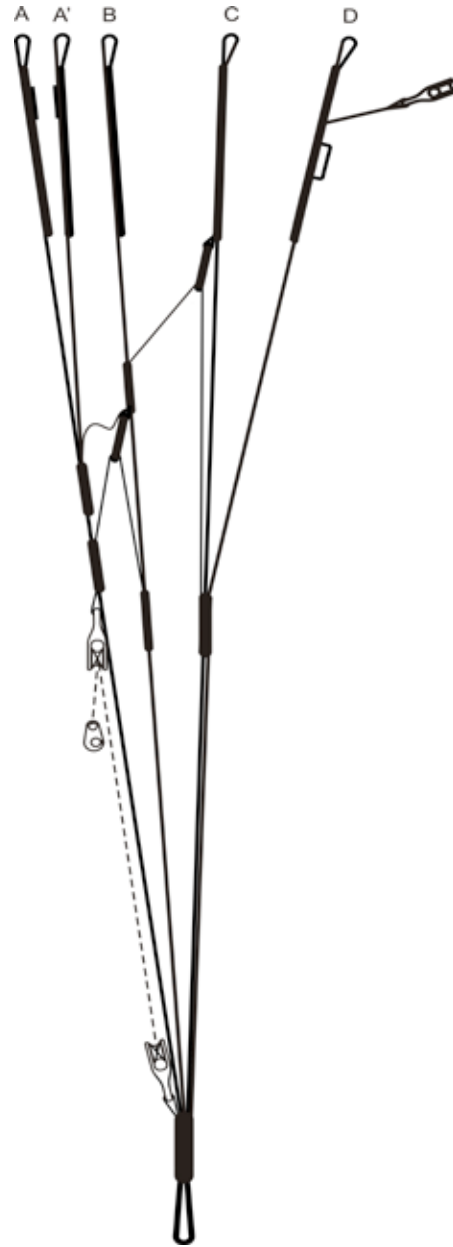

**DATOS TÉCNICOS COLORES**

BOBY	1	GREEN	COLOR EXTRADÓS	REF: 551
	4	GREEN	COLOR INTRADÓS	REF: 551
	2	SUNFLOWER	CUERNO	REF: 921
	3	DRAGON RED	SOMBRA	REF: 636



SPICY	1	DRAGON RED	COLOR EXTRADÓS	REF: 636
	4	DRAGON RED	COLOR INTRADÓS	REF: 636
	2	DARK RED	CUERNO	REF: 615
	3	WHITE	SOMBRA	REF: 001

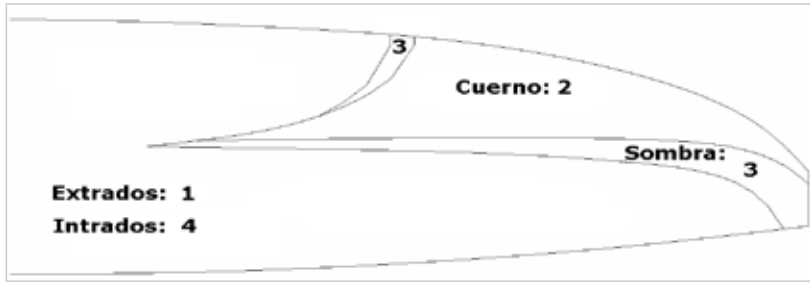

SUNNY	1	ORANGE	COLOR EXTRADÓS	REF: 744
	4	ORANGE	COLOR INTRADÓS	REF: 744
	2	DARK GREY	CUERNO	REF: 121
	3	WHITE	SOMBRA	REF: 001



AZUR	1	DEEP BLUE	COLOR EXTRADÓS	REF: 354
	4	DEEP BLUE	COLOR INTRADÓS	REF: 354
	2	SUNFLOWER	CUERNO	REF: 921
	3	ORANGE	SOMBRA	REF: 744



**CARGA ALAR**

KOYOT 31		28		26		24		22	
P.T.V.	KG/M2	P.T.V.	KG/M2	P.T.V.	KG/M2	P.T.V.	KG/M2	P.T.V.	KG/M2
135	= 4,35	115	= 4,11	95	= 3,65	85	= 3,54	65	= 2,95
134	= 4,32	114	= 4,07	94	= 3,62	84	= 3,50	64	= 2,91
133	= 4,29	113	= 4,04	93	= 3,58	83	= 3,46	63	= 2,86
132	= 4,26	112	= 4	92	= 3,54	82	= 3,42	62	= 2,82
131	= 4,23	111	= 3,96	91	= 3,50	81	= 3,38	61	= 2,77
130	= 4,19	110	= 3,93	90	= 3,46	80	= 3,33	60	= 2,73
129	= 4,16	109	= 3,89	89	= 3,42	79	= 3,29	59	= 2,68
128	= 4,13	108	= 3,86	88	= 3,38	78	= 3,25	58	= 2,64
127	= 4,10	107	= 3,82	87	= 3,35	77	= 3,21	57	= 2,59
126	= 4,06	106	= 3,79	86	= 3,31	76	= 3,17	56	= 2,55
125	= 4,03	105	= 3,75	85	= 3,27	75	= 3,13	55	= 2,50
124	= 4	104	= 3,71	84	= 3,23	74	= 3,08	54	= 2,45
123	= 3,97	103	= 3,68	83	= 3,19	73	= 3,04	53	= 2,41
122	= 3,94	102	= 3,64	82	= 3,15	72	= 3	52	= 2,36
121	= 3,90	101	= 3,61	81	= 3,12	71	= 2,96	51	= 2,32
120	= 3,87	100	= 3,57	80	= 3,08	70	= 2,92	50	= 2,27
119	= 3,84	99	= 3,54	79	= 3,04	69	= 2,88	49	= 2,23
118	= 3,81	98	= 3,50	78	= 3	68	= 2,83	48	= 2,18
117	= 3,77	97	= 3,46	77	= 2,96	67	= 2,79	47	= 2,14
116	= 3,74	96	= 3,43	76	= 2,92	66	= 2,75	46	= 2,09
115	= 3,71	95	= 3,39	75	= 2,88	65	= 2,71	45	= 2,05
114	= 3,68	94	= 3,36			64	= 2,67		
113	= 3,65	93	= 3,32			63	= 2,63		
112	= 3,61	92	= 3,29			62	= 2,58		
111	= 3,58	91	= 3,25			61	= 2,54		
110	= 3,55	90	= 3,21			60	= 2,50		

**DATOS TÉCNICOS SUSPENTES**

KOYOT		22												
REF.	CODE	CM.	REF.	CODE	CM.	REF.	CODE	CM.	REF.	CODE	CM.	REF.	CODE	
<b>A</b>			<b>B</b>			<b>C</b>			<b>D</b>			<b>BRAKE</b>		
A1	TNL-080-YLW	89,5	B1	TNL-080-BLU	89,5	C1	TNL-080-BLU	72,5	D1	TNL-080-BLU	53,5	BR2	TNL-080-PNK	112,5
A2	TNL-080-YLW	85,5	B2	TNL-080-BLU	85,5	C2	TNL-080-BLU	67	D2	TNL-080-BLU	47	BR4	TNL-080-PNK	87
A3	TNL-080-YLW	86,5	B3	TNL-080-BLU	86	C3	TNL-080-BLU	68	D3	TNL-080-BLU	48,5	BR6	TNL-080-PNK	45
A4	TNL-080-YLW	88,5	B4	TNL-080-BLU	88	C4	TNL-080-BLU	71,5	D4	TNL-080-BLU	53	BR7	TNL-080-PNK	42,5
A6	TNL-080-YLW	88	B6	TNL-080-BLU	87,5	C6	TNL-080-BLU	71	D6	TNL-080-BLU	52,5	BR8	TNL-080-PNK	87,5
A7	TNL-080-YLW	84	B7	TNL-080-BLU	83,5	C7	TNL-080-BLU	65,5	D7	TNL-080-BLU	44,5	BR9	TNL-080-PNK	77
A8	TNL-080-YLW	169,5	B8	TNL-080-BLU	167	C8	TNL-080-BLU	131,5	D8	TNL-080-BLU	92	BR10	TNL-080-PNK	76,5
A9	TNL-080-YLW	169	B9	TNL-080-BLU	167	C9	TNL-080-BLU	132	D9	TNL-080-BLU	93	BR11	TNL-080-PNK	73
A10	TNL-080-YLW	172	B10	TNL-080-BLU	170,5	C10	TNL-080-BLU	137,5	D10	TNL-080-BLU	101	BR12	TNL-080-PNK	73,5
A12	TNL-080-YLW	160	B12	TNL-080-BLU	155	C12	TNL-080-BLU	133,5	D12	TNL-080-BLU	90,5	BR13	TNL-080-PNK	81,5
A13	TNL-080-YLW	155	B13	TNL-080-BLU	150,5	C13	TNL-080-BLU	128	D13	TNL-080-BLU	84	BR14	TNL-080-PNK	59
A14	TNL-080-YLW	152	B14	TNL-080-BLU	148	C14	TNL-080-BLU	125,5	D14	TNL-080-BLU	82,5	BR15	TNL-080-PNK	52
A15	TNL-080-YLW	150	B15	TNL-080-BLU	139	C15	TNL-080-BLU	115	D15	TNL-080-BLU	77	BR16	TNL-080-PNK	52
A16	TNL-080-YLW	145,5	B16	TNL-080-BLU	135	C16	TNL-080-BLU	111,5	D16	TNL-080-BLU	72			
A17	TNL-080-YLW	142,5	B17	TNL-080-BLU	132	C17	TNL-080-BLU	109	D17	TNL-080-BLU	71			
A19	TNL-080-RED	129,5	B19	TNL-080-RED	128	C19	TNL-080-RED	130,5						
2 A1	TNL-140-YLW	109,5	2 B1	TNL-140-BLU	109	2 C1	TNL-140-BLU	85,5	2 D1	TNL-140-BLU	84,5	2 BR1	TNL-080-PNK	139,5
2 A2	TNL-140-YLW	107,5	2 B2	TNL-140-BLU	107	2 C2	TNL-140-BLU	83,5	2 D2	TNL-140-BLU	82	2 BR2	TNL-080-PNK	161,5
2 A3	TNL-140-YLW	153	2 B3	TNL-140-BLU	151,5	2 C3	TNL-140-BLU	118,5	2 D3	TNL-140-BLU	89,5	2 BR3	TNL-080-PNK	93
2 A4	TNL-140-YLW	65	2 B4	TNL-140-BLU	65,5	2 C4	TNL-140-BLU	50	2 D4	TNL-140-BLU	38,5	2 BR4	TNL-080-PNK	96
2 A5	TNL-140-YLW	84,5	2 B5	TNL-140-BLU	78	2 C5	TNL-140-BLU	62,5	2 D5	TNL-140-BLU	115	2 BR5	TNL-080-PNK	65,5
2 A6	TNL-140-YLW	81,5	2 B6	TNL-140-BLU	83	2 C6	TNL-140-BLU	69	2 D6	TNL-140-BLU	115	2 BR6	TNL-080-PNK	115
3 A1	TNL-280-YLW	403	3 B1	TNL-280-BLU	396	3 C1	TNL-280-BLU	440	3 D1	TNL-220-BLU	471,5	3 BR1	TNL-140-PNK	245
3 A2	TNL-220-YLW	355	3 B2	TNL-220-BLU	351	3 C2	TNL-220-BLU	404	3 D2	TNL-220-BLU	465	3 BR2	TNL-140-PNK	263,5
3 A3	TNL-220-YLW	342,5	3 B3	TNL-220-BLU	350	3 C3	TNL-220-BLU	390,5				3 BR3	TNL-140-PNK	305
			STAB	TNL-140-PNK	410							4 BR1	TNL-400-PNK	206,5
													POINT AT:	186,5

**DATOS TÉCNICOS SUSPENTES**

KOYOT			24											
REF.	CODE	CM.	REF.	CODE	CM.	REF.	CODE	CM.	REF.	CODE	CM.	REF.	CODE	
<b>A</b>			<b>B</b>			<b>C</b>			<b>D</b>			<b>BRAKE</b>		
A1	TNL-080-YLW	94,5	B1	TNL-080-BLU	94,5	C1	TNL-080-BLU	76,5	D1	TNL-080-BLU	56,5	BR2	TNL-080-PNK	119
A2	TNL-080-YLW	90	B2	TNL-080-BLU	90	C2	TNL-080-BLU	71	D2	TNL-080-BLU	50	BR4	TNL-080-PNK	91,5
A3	TNL-080-YLW	91	B3	TNL-080-BLU	91	C3	TNL-080-BLU	72	D3	TNL-080-BLU	51	BR6	TNL-080-PNK	47,5
A4	TNL-080-YLW	93,5	B4	TNL-080-BLU	93	C4	TNL-080-BLU	75,5	D4	TNL-080-BLU	56	BR7	TNL-080-PNK	45
A6	TNL-080-YLW	93	B6	TNL-080-BLU	92,5	C6	TNL-080-BLU	75	D6	TNL-080-BLU	55,5	BR8	TNL-080-PNK	92,5
A7	TNL-080-YLW	88,5	B7	TNL-080-BLU	88,5	C7	TNL-080-BLU	69,5	D7	TNL-080-BLU	47,5	BR9	TNL-080-PNK	81,5
A8	TNL-080-YLW	179	B8	TNL-080-BLU	176,5	C8	TNL-080-BLU	139	D8	TNL-080-BLU	97,5	BR10	TNL-080-PNK	80,5
A9	TNL-080-YLW	178,5	B9	TNL-080-BLU	176,5	C9	TNL-080-BLU	139,5	D9	TNL-080-BLU	98	BR11	TNL-080-PNK	77
A10	TNL-080-YLW	182	B10	TNL-080-BLU	180	C10	TNL-080-BLU	145	D10	TNL-080-BLU	107	BR12	TNL-080-PNK	77,5
A12	TNL-080-YLW	169	B12	TNL-080-BLU	163,5	C12	TNL-080-BLU	141	D12	TNL-080-BLU	95,5	BR13	TNL-080-PNK	86
A13	TNL-080-YLW	163,5	B13	TNL-080-BLU	159	C13	TNL-080-BLU	135,5	D13	TNL-080-BLU	88,5	BR14	TNL-080-PNK	62,5
A14	TNL-080-YLW	160,5	B14	TNL-080-BLU	156	C14	TNL-080-BLU	132,5	D14	TNL-080-BLU	87,5	BR15	TNL-080-PNK	55
A15	TNL-080-YLW	158,5	B15	TNL-080-BLU	146,5	C15	TNL-080-BLU	121,5	D15	TNL-080-BLU	81	BR16	TNL-080-PNK	55
A16	TNL-080-YLW	153,5	B16	TNL-080-BLU	142,5	C16	TNL-080-BLU	117,5	D16	TNL-080-BLU	76			
A17	TNL-080-YLW	150,5	B17	TNL-080-BLU	139,5	C17	TNL-080-BLU	115,5	D17	TNL-080-BLU	75			
A19	TNL-080-RED	137	B19	TNL-080-RED	135,5	C19	TNL-080-RED	137,5						
2 A1	TNL-140-YLW	115,5	2 B1	TNL-140-BLU	115	2 C1	TNL-140-BLU	90,5	2 D1	TNL-140-BLU	89,5	2 BR1	TNL-080-PNK	147,5
2 A2	TNL-140-YLW	113,5	2 B2	TNL-140-BLU	113	2 C2	TNL-140-BLU	88	2 D2	TNL-140-BLU	87	2 BR2	TNL-080-PNK	170,5
2 A3	TNL-140-YLW	162	2 B3	TNL-140-BLU	160	2 C3	TNL-140-BLU	125	2 D3	TNL-140-BLU	94,5	2 BR3	TNL-080-PNK	278
2 A4	TNL-140-YLW	68,5	2 B4	TNL-140-BLU	69,5	2 C4	TNL-140-BLU	52,5	2 D4	TNL-140-BLU	40,5	2 BR4	TNL-080-PNK	101
2 A5	TNL-140-YLW	89	2 B5	TNL-140-BLU	82,5	2 C5	TNL-140-BLU	66	2 D5	TNL-140-BLU	121,5	2 BR5	TNL-080-PNK	68,5
2 A6	TNL-140-YLW	86	2 B6	TNL-140-BLU	87,5	2 C6	TNL-140-BLU	73	2 D6	TNL-140-BLU	121,5	2 BR6	TNL-080-PNK	120
3 A1	TNL-280-YLW	425,5	3 B1	TNL-280-BLU	418,5	3 C1	TNL-280-BLU	464,5	3 D1	TNL-220-BLU	498,5	3 BR1	TNL-140-PNK	258,5
3 A2	TNL-220-YLW	375,5	3 B2	TNL-220-BLU	370,5	3 C2	TNL-220-BLU	427	3 D2	TNL-220-BLU	491,5	3 BR2	TNL-140-PNK	278
3 A3	TNL-220-YLW	362	3 B3	TNL-220-BLU	370	3 C3	TNL-220-BLU	413				3 BR3	TNL-140-PNK	322,5
			STAB	TNL-140-PNK	433							4 BR1	TNL-400-PNK	215,5
													POINT AT:	195,5



**DATOS TÉCNICOS SUSPENTES**

KOYOT			26											
REF.	CODE	CM.	REF.	CODE	CM.	REF.	CODE	CM.	REF.	CODE	CM.	REF.	CODE	
<b>A</b>			<b>B</b>			<b>C</b>			<b>D</b>			<b>BRAKE</b>		
A1	TNL-080-YLW	98,5	B1	TNL-080-BLU	98,5	C1	TNL-080-BLU	80	D1	TNL-080-BLU	59	BR2	TNL-080-PNK	124,5
A2	TNL-080-YLW	94	B2	TNL-080-BLU	93,5	C2	TNL-080-BLU	74	D2	TNL-080-BLU	52	BR4	TNL-080-PNK	95,5
A3	TNL-080-YLW	95	B3	TNL-080-BLU	94,5	C3	TNL-080-BLU	75	D3	TNL-080-BLU	53	BR6	TNL-080-PNK	49,5
A4	TNL-080-YLW	97	B4	TNL-080-BLU	97	C4	TNL-080-BLU	78,5	D4	TNL-080-BLU	58	BR7	TNL-080-PNK	47
A6	TNL-080-YLW	97	B6	TNL-080-BLU	96,5	C6	TNL-080-BLU	78	D6	TNL-080-BLU	58	BR8	TNL-080-PNK	96,5
A7	TNL-080-YLW	92	B7	TNL-080-BLU	92	C7	TNL-080-BLU	72	D7	TNL-080-BLU	49	BR9	TNL-080-PNK	85
A8	TNL-080-YLW	186,5	B8	TNL-080-BLU	183,5	C8	TNL-080-BLU	144	D8	TNL-080-BLU	100	BR10	TNL-080-PNK	84
A9	TNL-080-YLW	186	B9	TNL-080-BLU	183,5	C9	TNL-080-BLU	145	D9	TNL-080-BLU	102	BR11	TNL-080-PNK	80
A10	TNL-080-YLW	189	B10	TNL-080-BLU	187,5	C10	TNL-080-BLU	151	D10	TNL-080-BLU	111,5	BR12	TNL-080-PNK	81
A12	TNL-080-YLW	176	B12	TNL-080-BLU	170,5	C12	TNL-080-BLU	147	D12	TNL-080-BLU	99,5	BR13	TNL-080-PNK	89,5
A13	TNL-080-YLW	170,5	B13	TNL-080-BLU	165,5	C13	TNL-080-BLU	141	D13	TNL-080-BLU	92,5	BR14	TNL-080-PNK	65
A14	TNL-080-YLW	167	B14	TNL-080-BLU	162,5	C14	TNL-080-BLU	138	D14	TNL-080-BLU	91	BR15	TNL-080-PNK	57,5
A15	TNL-080-YLW	165	B15	TNL-080-BLU	152,5	C15	TNL-080-BLU	162,5	D15	TNL-080-BLU	84,5	BR16	TNL-080-PNK	57
A16	TNL-080-YLW	160	B16	TNL-080-BLU	148,5	C16	TNL-080-BLU	122,5	D16	TNL-080-BLU	79,5			
A17	TNL-080-YLW	157	B17	TNL-080-BLU	145,5	C17	TNL-080-BLU	120,5	D17	TNL-080-BLU	78,5			
A19	TNL-080-RED	76,5	B19	TNL-080-RED	75,5	C19	TNL-080-RED	84						
2 A1	TNL-140-YLW	120	2 B1	TNL-140-BLU	120	2 C1	TNL-140-BLU	94	2 D1	TNL-140-BLU	93	2 BR1	TNL-080-PNK	154
2 A2	TNL-140-YLW	118	2 B2	TNL-140-BLU	118	2 C2	TNL-140-BLU	92	2 D2	TNL-140-BLU	90,5	2 BR2	TNL-080-PNK	177,5
2 A3	TNL-140-YLW	168,5	2 B3	TNL-140-BLU	166	2 C3	TNL-140-BLU	129,5	2 D3	TNL-140-BLU	97	2 BR3	TNL-080-PNK	102
2 A4	TNL-140-YLW	71,5	2 B4	TNL-140-BLU	72,5	2 C4	TNL-140-BLU	55	2 D4	TNL-140-BLU	42	2 BR4	TNL-080-PNK	105,5
2 A5	TNL-140-YLW	92,5	2 B5	TNL-140-BLU	85,5	2 C5	TNL-140-BLU	68,5	2 D5	TNL-140-BLU	126	2 BR5	TNL-080-PNK	71,5
2 A6	TNL-140-YLW	90	2 B6	TNL-140-BLU	91,5	2 C6	TNL-140-BLU	75,5	2 D6	TNL-140-BLU	125,5	2 BR6	TNL-080-PNK	120,5
3 A1	TNL-280-YLW	442	3 B1	TNL-280-BLU	434,5	3 C1	TNL-280-BLU	482,5	3 D1	TNL-220-BLU	517,5	3 BR1	TNL-140-PNK	269
3 A2	TNL-220-YLW	390	3 B2	TNL-220-BLU	385,5	3 C2	TNL-220-BLU	445	3 D2	TNL-220-BLU	512,5	3 BR2	TNL-140-PNK	289,5
3 A3	TNL-220-YLW	376,5	3 B3	TNL-220-BLU	385	3 C3	TNL-220-BLU	429				3 BR3	TNL-140-PNK	335,5
			STAB	TNL-140-PNK	516							4 BR1	TNL-400-PNK	223,5
													POINT AT:	203,5

**DATOS TÉCNICOS SUSPENTES**

KOYOT		28												
REF.	CODE	CM.	REF.	CODE	CM.	REF.	CODE	CM.	REF.	CODE	CM.	REF.	CODE	
<b>A</b>			<b>B</b>			<b>C</b>			<b>D</b>			<b>BRAKE</b>		
A1	TNL-080-YLW	102	B1	TNL-080-BLU	102	C1	TNL-080-BLU	83	D1	TNL-080-BLU	61	BR2	TNL-080-PNK	129,5
A2	TNL-080-YLW	97,5	B2	TNL-080-BLU	97	C2	TNL-080-BLU	76,5	D2	TNL-080-BLU	54	BR4	TNL-080-PNK	99
A3	TNL-080-YLW	98,5	B3	TNL-080-BLU	98	C3	TNL-080-BLU	78	D3	TNL-080-BLU	55	BR6	TNL-080-PNK	51
A4	TNL-080-YLW	101	B4	TNL-080-BLU	100,5	C4	TNL-080-BLU	81,5	D4	TNL-080-BLU	60	BR7	TNL-080-PNK	48,5
A6	TNL-080-YLW	100,5	B6	TNL-080-BLU	100	C6	TNL-080-BLU	81	D6	TNL-080-BLU	60	BR8	TNL-080-PNK	100
A7	TNL-080-YLW	95,5	B7	TNL-080-BLU	95,5	C7	TNL-080-BLU	75	D7	TNL-080-BLU	51	BR9	TNL-080-PNK	88
A8	TNL-080-YLW	193,5	B8	TNL-080-BLU	191	C8	TNL-080-BLU	150	D8	TNL-080-BLU	105	BR10	TNL-080-PNK	87
A9	TNL-080-YLW	193	B9	TNL-080-BLU	190,5	C9	TNL-080-BLU	150,5	D9	TNL-080-BLU	106	BR11	TNL-080-PNK	83
A10	TNL-080-YLW	196,5	B10	TNL-080-BLU	194,5	C10	TNL-080-BLU	156,5	D10	TNL-080-BLU	115,5	BR12	TNL-080-PNK	84
A12	TNL-080-YLW	183	B12	TNL-080-BLU	177	C12	TNL-080-BLU	152,5	D12	TNL-080-BLU	103,5	BR13	TNL-080-PNK	93
A13	TNL-080-YLW	177	B13	TNL-080-BLU	171,5	C13	TNL-080-BLU	146,5	D13	TNL-080-BLU	96	BR14	TNL-080-PNK	67,5
A14	TNL-080-YLW	173,5	B14	TNL-080-BLU	168,5	C14	TNL-080-BLU	143	D14	TNL-080-BLU	94,5	BR15	TNL-080-PNK	59,5
A15	TNL-080-YLW	171	B15	TNL-080-BLU	158,5	C15	TNL-080-BLU	131,5	D15	TNL-080-BLU	87,5	BR16	TNL-080-PNK	59
A16	TNL-080-YLW	166	B16	TNL-080-BLU	154	C16	TNL-080-BLU	127	D16	TNL-080-BLU	82,5			
A17	TNL-080-YLW	162,5	B17	TNL-080-BLU	150,5	C17	TNL-080-BLU	124,5	D17	TNL-080-BLU	81			
A19	TNL-080-RED	149	B19	TNL-080-RED	146,5	C19	TNL-080-RED	148,5						
2 A1	TNL-140-YLW	125	2 B1	TNL-140-BLU	124,5	2 C1	TNL-140-BLU	98	2 D1	TNL-140-BLU	96,5	2 BR1	TNL-080-PNK	160
2 A2	TNL-140-YLW	122,5	2 B2	TNL-140-BLU	122	2 C2	TNL-140-BLU	95,5	2 D2	TNL-140-BLU	94	2 BR2	TNL-080-PNK	184
2 A3	TNL-140-YLW	175	2 B3	TNL-140-BLU	172,5	2 C3	TNL-140-BLU	135	2 D3	TNL-140-BLU	102	2 BR3	TNL-080-PNK	106
2 A4	TNL-140-YLW	74	2 B4	TNL-140-BLU	75	2 C4	TNL-140-BLU	57	2 D4	TNL-140-BLU	44	2 BR4	TNL-080-PNK	109,5
2 A5	TNL-140-YLW	96	2 B5	TNL-140-BLU	89	2 C5	TNL-140-BLU	71,5	2 D5	TNL-140-BLU	131,5	2 BR5	TNL-080-PNK	73,5
2 A6	TNL-140-YLW	93	2 B6	TNL-140-BLU	94,5	2 C6	TNL-140-BLU	78,5	2 D6	TNL-140-BLU	131,5	2 BR6	TNL-080-PNK	130
3 A1	TNL-280-YLW	460	3 B1	TNL-280-BLU	452,5	3 C1	TNL-280-BLU	502	3 D1	TNL-220-BLU	538,5	3 BR1	TNL-140-PNK	278,5
3 A2	TNL-220-YLW	405,5	3 B2	TNL-220-BLU	400,5	3 C2	TNL-220-BLU	461,5	3 D2	TNL-220-BLU	531	3 BR2	TNL-140-PNK	300
3 A3	TNL-220-YLW	391	3 B3	TNL-220-BLU	400	3 C3	TNL-220-BLU	446				3 BR3	TNL-140-PNK	348,5
			STAB	TNL-140-PNK	467,5							4 BR1	TNL-400-PNK	229,5
													POINT AT:	209,5

**DATOS TÉCNICOS SUSPENTES**

KOYOT		31												
REF.	CODE	CM.	REF.	CODE	CM.	REF.	CODE	CM.	REF.	CODE	CM.	REF.	CODE	
<b>A</b>			<b>B</b>			<b>C</b>			<b>D</b>			<b>BRAKE</b>		
A1	TNL-080-YLW	107,5	B1	TNL-080-BLU	107	C1	TNL-080-BLU	87	D1	TNL-080-BLU	64,5	BR2	TNL-080-PNK	136,5
A2	TNL-080-YLW	102,5	B2	TNL-080-BLU	102	C2	TNL-080-BLU	80,5	D2	TNL-080-BLU	56,5	BR4	TNL-080-PNK	104
A3	TNL-080-YLW	103,5	B3	TNL-080-BLU	103	C3	TNL-080-BLU	82	D3	TNL-080-BLU	58	BR6	TNL-080-PNK	54
A4	TNL-080-YLW	106	B4	TNL-080-BLU	106	C4	TNL-080-BLU	86	D4	TNL-080-BLU	63,5	BR7	TNL-080-PNK	51
A6	TNL-080-YLW	106	B6	TNL-080-BLU	105	C6	TNL-080-BLU	85	D6	TNL-080-BLU	63	BR8	TNL-080-PNK	105
A7	TNL-080-YLW	100,5	B7	TNL-080-BLU	100,5	C7	TNL-080-BLU	78,5	D7	TNL-080-BLU	53,5	BR9	TNL-080-PNK	92,5
A8	TNL-080-YLW	203,5	B8	TNL-080-BLU	200,5	C8	TNL-080-BLU	158	D8	TNL-080-BLU	110,5	BR10	TNL-080-PNK	92
A9	TNL-080-YLW	203	B9	TNL-080-BLU	200,5	C9	TNL-080-BLU	158,5	D9	TNL-080-BLU	111,5	BR11	TNL-080-PNK	87,5
A10	TNL-080-YLW	206,5	B10	TNL-080-BLU	205	C10	TNL-080-BLU	165	D10	TNL-080-BLU	121,5	BR12	TNL-080-PNK	88,5
A12	TNL-080-YLW	192,5	B12	TNL-080-BLU	186	C12	TNL-080-BLU	160,5	D12	TNL-080-BLU	108,5	BR13	TNL-080-PNK	98
A13	TNL-080-YLW	186	B13	TNL-080-BLU	180,5	C13	TNL-080-BLU	154	D13	TNL-080-BLU	101	BR14	TNL-080-PNK	71
A14	TNL-080-YLW	182,5	B14	TNL-080-BLU	177,5	C14	TNL-080-BLU	150,5	D14	TNL-080-BLU	99,5	BR15	TNL-080-PNK	62,5
A15	TNL-080-YLW	180	B15	TNL-080-BLU	166,5	C15	TNL-080-BLU	138	D15	TNL-080-BLU	92	BR16	TNL-080-PNK	62,5
A16	TNL-080-YLW	174,5	B16	TNL-080-BLU	162	C16	TNL-080-BLU	134	D16	TNL-080-BLU	86,5			
A17	TNL-080-YLW	171	B17	TNL-080-BLU	158,5	C17	TNL-080-BLU	131	D17	TNL-080-BLU	85,5			
A19	TNL-080-RED	157	B19	TNL-080-RED	154	C19	TNL-080-RED	155,5						
2 A1	TNL-140-YLW	131,5	2 B1	TNL-140-BLU	131	2 C1	TNL-140-BLU	103	2 D1	TNL-140-BLU	101,5	2 BR1	TNL-080-PNK	168,5
2 A2	TNL-140-YLW	129	2 B2	TNL-140-BLU	128,5	2 C2	TNL-140-BLU	100,5	2 D2	TNL-140-BLU	98,5	2 BR2	TNL-080-PNK	194
2 A3	TNL-140-YLW	184	2 B3	TNL-140-BLU	182	2 C3	TNL-140-BLU	142	2 D3	TNL-140-BLU	107	2 BR3	TNL-080-PNK	111,5
2 A4	TNL-140-YLW	78	2 B4	TNL-140-BLU	79	2 C4	TNL-140-BLU	60	2 D4	TNL-140-BLU	46	2 BR4	TNL-080-PNK	115
2 A5	TNL-140-YLW	101	2 B5	TNL-140-BLU	93,5	2 C5	TNL-140-BLU	75	2 D5	TNL-140-BLU	138	2 BR5	TNL-080-PNK	77
2 A6	TNL-140-YLW	97,5	2 B6	TNL-140-BLU	99,5	2 C6	TNL-140-BLU	83	2 D6	TNL-140-BLU	138,5	2 BR6	TNL-080-PNK	137
3 A1	TNL-280-YLW	484	3 B1	TNL-280-BLU	476	3 C1	TNL-280-BLU	528,5	3 D1	TNL-220-BLU	567	3 BR1	TNL-140-PNK	293
3 A2	TNL-220-YLW	427	3 B2	TNL-220-BLU	421,5	3 C2	TNL-220-BLU	486	3 D2	TNL-220-BLU	559	3 BR2	TNL-140-PNK	315,5
3 A3	TNL-220-YLW	412	3 B3	TNL-220-BLU	421	3 C3	TNL-220-BLU	469,5				3 BR3	TNL-140-PNK	367
			STAB	TNL-140-PNK	492							4 BR1	TNL-400-PNK	240,5
												POINT AT:	220,5	

**NIVIUK KOYOT 22**

LONGITUD LÍNEAS CM.						
	<b>A</b>	<b>B</b>	<b>C</b>	<b>D</b>	<b>RIB</b>	<b>BR</b>
1	598	590,5	594	605,5	2	680,5
2	594	586,5	588,5	598,5	4	655
3	592,5	584,5	587	597,5	6	634,5
4	594,5	586,5	590,5	602	7	632
6	592	585,5	589,5	602,5	8	627
7	588	581,5	583,5	594,5	9	616,5
8	585,5	579	581	591	10	616
9	585	579	581,5	592	11	615
10	588	582,5	587	599,5	12	616
12	583	579	582	591,5	13	623,5
13	577,5	574,5	576,5	585	14	612
14	574,5	571,5	574	583	15	605
15	569,5	567,5	570	578	16	605
16	565	563,5	566,5	572,5	17	609,5
17	562	560,5	563,5	571,5		
STB	537	535,5	538			

LONGITUD BANDAS CM.					
	<b>A</b>	<b>B</b>	<b>C</b>	<b>D</b>	
	47	47	47	47	STANDARD
	36,5	39	43	47	ACELERADO

**NIVIUK KOYOT 24**

LONGITUD LÍNEAS CM.						
	<b>A</b>	<b>B</b>	<b>C</b>	<b>D</b>	<b>RIB</b>	<b>BR</b>
1	632,5	625	628,5	642	2	718,5
2	628,5	620,5	622,5	635	4	690,5
3	626,5	619,5	621,5	633,5	6	669,5
4	629,5	621,5	625	638,5	7	667
6	628	620	623,5	638,5	8	661
7	623	616	618,5	630,5	9	650
8	620,5	613,5	615,5	626,5	10	649,5
9	620	613,5	616	626,5	11	648,5
10	623,5	617	621,5	635,5	12	649
12	617,5	613	617	626,5	13	657,5
13	611,5	608	611	619,5	14	646
14	608,5	605,5	608,5	618,5	15	638,5
15	603,5	601	604	612	16	638,5
16	598,5	597	600	607	17	632,5
17	595,5	594	598	606		
STB	568,5	567,5	569,5			

LONGITUD BANDAS CM.					
	<b>A</b>	<b>B</b>	<b>C</b>	<b>D</b>	
	47	47	47	47	STANDARD
	36	38	42	47	ACELERADO

**NIVIUK KOYOT 26**

LONGITUD LÍNEAS CM.						
	<b>A</b>	<b>B</b>	<b>C</b>	<b>D</b>	<b>RIB</b>	<b>BR</b>
1	658,5	650,5	654	667	2	755
2	653,5	645,5	648	660	4	725,5
3	652,5	644,5	646,5	658,5	6	702,5
4	654,5	647	650	663,5	7	700
6	653,5	645,5	649,5	664,5	8	693,5
7	648,5	641	643,5	655,5	9	682,5
8	646	639	641,5	652,5	10	681
9	645,5	638,5	642	653,5	11	681
10	648,5	642,5	648	663,5	12	682
12	643	638	642	652	13	690,5
13	637,5	633,5	636	645	14	678
14	634	630	633	643,5	15	670,5
15	629	626	628,5	637	16	669,5
16	624	622	624,5	632	17	662,5
17	621	619	622,5	630,5		
STB	591,5	590,5	599,5			

LONGITUD BANDAS CM.					
	<b>A</b>	<b>B</b>	<b>C</b>	<b>D</b>	
	47	47	47	47	STANDARD
	36	38	42	47	ACELERADO

**NIVIUK KOYOT 28**

LONGITUD LÍNEAS CM.						
	<b>A</b>	<b>B</b>	<b>C</b>	<b>D</b>	<b>RIB</b>	<b>BR</b>
1	684	675,5	680	692	2	774,5
2	679,5	670,5	673	685,5	4	744
3	678	669,5	672,5	684	6	719,5
4	680,5	672	676	689	7	717,5
6	678	669,5	674	689,5	8	712,5
7	673	665,5	668,5	680,5	9	700
8	670,5	663,5	665,5	676,5	10	699
9	669,5	663	666	677,5	11	698,5
10	673,5	667	672	687	12	700
12	667	663	666,5	677,5	13	709
13	661	657,5	660,5	670	14	695,5
14	658	654,5	657	668,5	15	687,5
15	652	650	652,5	661,5	16	687
16	647	645,5	648	656,5	17	682
17	643,5	642	645,5	654,5		
STB	614,5	612,5	614,5			

LONGITUD BANDAS CM.					
	<b>A</b>	<b>B</b>	<b>C</b>	<b>D</b>	
	47	47	47	47	STANDARD
	36	38	42	47	ACELERADO

LONGITUD LÍNEAS CM.

	<b>A</b>	<b>B</b>	<b>C</b>	<b>D</b>	<b>RIB</b>	<b>BR</b>
1	719	709,5	714	728,5	2	816
2	714	704	707,5	720,5	4	783,5
3	712,5	703	706,5	718,5	6	759
4	715	706	710,5	724,5	7	755,5
6	713	704,5	709	724,5	8	749,5
7	707,5	700	702,5	715	9	737
8	705	697	699,5	711	10	736,5
9	704	697	700,5	711,5	11	735,5
10	707,5	701,5	706,5	722	12	736,5
12	701	696,5	700,5	711,5	13	745,5
13	694,5	691,5	694	703,5	14	732
14	691	687,5	690,5	702	15	724
15	685	682,5	686	695	16	723,5
16	679,5	678	681,5	689,5	17	724
17	675,5	674,5	678,5	688		
STB	646,5	643,5	644,5			

LONGITUD BANDAS CM.

	<b>A</b>	<b>B</b>	<b>C</b>	<b>D</b>	
	47	47	47	47	STANDARD
	36	38	42	47	ACELERADO

## DATOS TÉCNICOS SUSPENTAJE

CÓDIGO MATERIAL	TEJIM NIVIUK LINES	TNL	TNL	TNL	TNL	TNL
CÓDIGO CARGA	KG	080	140	220	280	400
CÓDIGO COLOR	F/YELLOW	YLW	YLW	YLW	YLW	
	S/BLUE	BLU	BLU	BLU	BLU	
	PINK	PNK	PNK			PNK
DIÁMETRO EN M/M	Ø	1,1	1,4	1,6	1,8	2,3
MATERIAL DEL ALMA		TECHNORA	TECHNORA	TECHNORA	TECHNORA	TECHNORA
MATERIAL DE LA FUNDA		POLYESTER	POLYESTER	POLYESTER	POLYESTER	POLYESTER
PESO POR METRO G/M	TOTAL	1,1	1,96	2,35	2,7	4
	ALMA	0,45	0,76	1,22	1,55	2,23
	FUNDA	0,65	1,2	1,13	1,15	1,77
CARGA DE RUPTURA	MÍN DAN	80	140	220	280	460
	MÁX DAN	92	160	250	320	470
RESISTENCIA DESPUÉS DE 5.000 CICLOS DE TORSIÓN	TEST DHV DAN	36,7	76,1	114,2	134,7	160,1
ALARGAMIENTO CON	5 DAN EN %	0,3	0,2	0,2	0,2	0,05
	10 DAN EN %	0,5	0,3	0,3	0,3	0,1
	15 DAN EN %	0,7	0,5	0,5	0,4	0,2
	20 DAN EN %	1	0,6	0,6	0,4	0,2
	25 DAN EN %	1,3	0,8	0,7	0,5	0,3
	50 DAN EN %	2,3	1,5	1,2	0,9	0,6
	75 DAN EN %	2,8	2,3	1,8	1,3	0,8
	100 DAN EN %		2,7	2,2	1,7	1,1
	125 DAN EN %		3,2	2,7	2	1,4
	150 DAN EN %			3	2,3	1,7
	175 DAN EN %			3,3	2,7	2
	200 DAN EN %			3,8	2,8	2,2
ALARGAMIENTO CON CARGA MÁXIMA EN %		3	3,4	4	4,1	4,6
1 DAN = 10 N = CA. 1 KG.						

**DATOS TÉCNICOS TEJIDO EXTRADÓS****DESCRIPCIÓN**

SKYTEX 45 EVOLUTION	REF. : F09092 - E85A
TEJIDO	9092
ACABADO FINAL	SIDE COATED (POLYURETHANE)
TIPO DE HILADO	POLYAMIDE 6.6 HIGH TENACITY – 33 DTEX
ANCHO	158 CM
PATRÓN	RIP STOP

**ESPECIFICACIONES**

PESO TEJIDO ACABADO	G/SQM	ISO 2286-2	45 +/-2
RESISTENCIA DESGARRO - URDIMBRE	DAN	ISO 4674	1 MINI
RESISTENCIA DESGARRO - TRAMA	DAN	ISO 4674	2 MINI
ALARGAMIENTO EN DIAGONAL CON 3 LBS	% MÉTODO INTERNO NCV 044		4,5 +/-2
ALARGAMIENTO EN DIAGONAL CON 5 LBS	% MÉTODO INTERNO NCV 044		13 +/-2
ALARGAMIENTO EN DIAGONAL CON 10 LBS	% MÉTODO INTERNO NCV 044		19 +/-4
FUERZA DE RUPTURA	DAN/5 CM	ISO 1421	40
DIRECCIÓN URDIMBRE			
FUERZA DE RUPTURA DIRECCIÓN TRAMA	DAN/5 CM	ISO 1421	33
RESISTENCIA POROSIDAD	1/SQM/MN	2000 PA	20
	* BAJO	100 CM2	
	SUPERFÍCIE		

**DATOS TÉCNICOS COLOR**

DEEP BLUE	REF. 354	UV 5-6
GREEN	REF. 551	UV 5
GOLD	REF. 939	UV 5-6
SUNFLOWER	REF. 921	UV 5-6
ORANGE	REF. 744	UV 5
DRAGÓN RED	REF. 636	UV 5-6
WHITE	REF. 001	UV 4
GREY	REF. 120	UV 5
DARK GREY	REF. 121	UV 5-6
BLACK	REF. 102	UV 5-6
DARK RED	REF. 615	UV 4-5

**DATOS TÉCNICOS TEJIDO INTRADÓS****DESCRIPCIÓN**

SKYTEX 40 CLASSIC	REF. : F09017 - E38A
TEJIDO	9017
ACABADO FINAL	SIDE COATED (POLYURETHANE)
TIPO DE HILADO	POLYAMIDE 6.6 HIGH TENACITY – 33 DTEX
ANCHO	158 CM
PATRÓN	RIP STOP

**ESPECIFICACIONES**

PESO TEJIDO ACABADO	G/SQM	ISO 2286-2	40 +/-2
RESISTENCIA DESGARRO - URDIMBRE	DAN	ISO 4674	2,8 +/-1
RESISTENCIA DESGARRO - TRAMA	DAN	ISO 4674	2,8 +/-1
ALARGAMIENTO EN DIAGONAL CON 3 LBS	% MÉTODO INTERNO NCV 044		5 +/-3
ALARGAMIENTO EN DIAGONAL CON 5 LBS	% MÉTODO INTERNO NCV 044		12,5 +/-4
ALARGAMIENTO EN DIAGONAL CON 10 LBS	% MÉTODO INTERNO NCV 044		24 +/-4
FUERZA DE RUPTURA	DAN/5 CM	ISO 1421	38 MINI
DIRECCIÓN URDIMBRE			
FUERZA DE RUPTURA DIRECCIÓN TRAMA	DAN/5 CM	ISO 1421	38 MINI
RESISTENCIA POROSIDAD	1/SQM/MN	2000 PA	40 MÁX
	* BAJO	100 CM2	
	SUPERFÍCIE		

**DATOS TÉCNICOS COLOR**

DEEP BLUE	REF. 354	UV 5-6
GREEN	REF. 551	UV 5
GOLD	REF. 939	UV 5-6
SUNFLOWER	REF. 921	UV 5-6
ORANGE	REF. 744	UV 5
DRAGÓN RED	REF. 636	UV 5-6
WHITE	REF. 001	UV 4
GREY	REF. 120	UV 5
DARK GREY	REF. 121	UV 5-6
BLACK	REF. 102	UV 5-6
DARK RED	REF. 615	UV 4-5



## DATOS TÉCNICOS MAILLON

### DESCRIPCIÓN

MAILLON	DELTA
REF.	MR14
MATERIAL	ACERO INOX
DIÁMETRO	4,3 M/M
PESO	12 G/PC

### ESPECIFICACIONES TÉCNICAS

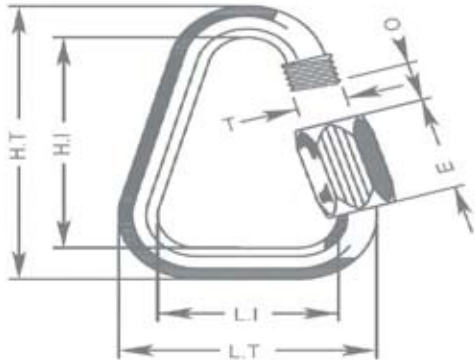

DIMENSIONES	M/M
L.T.	28
L.I.	20
H.T.	38
H.I.	30
O	4
E	11
T	4
CARGA	KG
TRABAJO	150
ROTURA	750

### MATERIAL

AISI 304 ACERO INOXIDABLE STANDARD

**CIERRE POR ROSCADO MANUAL Y COMPLETO DE LA TUERCA PARA GARANTIZAR UNA SEGURIDAD ÓPTIMA (EL ROSCADO DEBE DE RESULTAR OBVIO).**

**CONTROL SISTEMÁTICO DE LOS CIERRES DE CADA MAILLON RAPIDE ANTES DE CADA VUELO.**

## DATOS TÉCNICOS HILO

NOMBRE	SERAFIL
Nº DE REFERENCIA	40
MATERIAL	POLYESTER
ACABADO	SILK
DENSIDAD LINEAL	NM 41 / 3 (DTEX 244 * 3)
RESISTENCIA A LA TRACCIÓN	4.500 CN
ELONGACIÓN	17,00%

NOMBRE	SERAFIL
Nº DE REFERENCIA	60
MATERIAL	POLYESTER
ACABADO	SILK
DENSIDAD LINEAL	NM 61 / 3 (DTEX 163 * 3)
RESISTENCIA A LA TRACCIÓN	3.000 CN
ELONGACIÓN	17,00%

### PROPIEDADES SERAFIL

SOLIDEZ A LA LUZ ARTIFICIAL	ISO 105 B02	> 5 - 6
SOLIDEZ AL SUDOR	ISO 105 E04	> 4
SOLIDEZ AL LAVADO	ISO 105 C04	> 3
SOLIDEZ AL FROTAMIENTO EN SECO	ISO 105 X12	> 4
SOLIDEZ AL LAVADO EN SECO	ISO 105 D01	> 3 - 4

TRATAMIENTO DE REPELENCIA AL AGUA	WR
-----------------------------------	----

NOMBRE	BONDED NYLON
Nº DE REFERENCIA	N/F-66
MATERIAL	NYLON
ACABADO	SILK
DENSIDAD LINEAL	210D / 6
RESISTENCIA A LA TRACCIÓN	9,7 KG
ELONGACIÓN	25/30 %

## DATOS TÉCNICOS BANDAS

### BANDAS

REFERENCIA	G-R 22
MATERIAL	POLYESTER
ANCHO	22 M/M
GRUESO	1,52 M/M
RESISTENCIA A LA TRACCIÓN	1.100 DAN
ALARGAMIENTO	MÁX. 15%
PESO	25 G/M
COLOR	NEGRO

### INDICADOR COLOR

REFERENCIA	IC-G 1-2
MATERIAL	POLYESTER
ANCHO	70 M/M
GRUESO	0,80 M/M
RESISTENCIA A LA TRACCIÓN	130 DN
ALARGAMIENTO	35%
PESO	32 G/M

### CINTAS DE CARGA

REFERENCIA	LKI - 10
MATERIAL	NYLON
ANCHO	10 M/M
RESISTENCIA A LA TRACCIÓN	84 KG
ALARGAMIENTO	25/35 %
PESO	3 G/M
COLOR	BLANCO

**nIVIUK**

[niviuk.com](http://niviuk.com)

The importance of small details