

# **DONNÉES TECHNIQUES R-BUS**



## DONNÉES TECHNIQUES

<b>R-BUS</b>			<b>37</b>	<b>40</b>
ALVÉOLES	NOMBRE		55	55
	FERMÉ		8	8
	CAISSONS		35	35
À PLAT	SURFACE	m <sup>2</sup>	37	40
	ENVERGURE	m	14,14	14,7
	ALLONGEMENT		5,4	5,4
PROJETÉE	SURFACE	m <sup>2</sup>	32,19	34,8
	ENVERGURE	m	11,54	12
	ALLONGEMENT		4,14	4,14
APLATISSEMENT		%	15	15
CORDE	MAXIMUM	m	3,24	3,37
	MINIMUM	m	0,71	0,74
	MOYENNE	m	2,62	2,72
SUSPENTES	MÈTRES TOTALES	m	426	444
	HAUTEUR	m	8,41	8,75
	NOMBRE		288	288
	PRINCIPALES		3+1/5/3/2	3+1/5/3/2
ÉLÉVATEURS	NOMBRE	4	A+A'/B/C/D	A+A'/B/C/D
	AFFICHEURS	m/m	105	105
	ACCÉLÉRATEUR	m/m	NON	NON
	DEBATTEMENT		OUI	OUI
POIDS TOTAL	MINIMUM	kg	150	210
EN VOL	MAXIMUM	kg	500	500
POIDS DE L'AILE		kg	7,6	8,1
HOMOLOGATION	8G MAXIMUM 328kg		EN 926-1	EN 926-1
	5,25G MAXIMUM 500kg		DGAC	DGAC

**MATÉRIAUX**

<b>VOILERIE</b>	<b>MATÉRIAUX</b>	<b>FABRICANT</b>
EXTRADOS	9017 E25	PORCHER IND (FRANCE)
INTRADOS	N 20 DMF	DOMINICO TEX CO. (CHINE)
PROFIL	9017 E29	PORCHER IND (FRANCE)
DIAGONALES	9017 E29	PORCHER IND (FRANCE)
POINT D'ATTACHE	LKI - 10	KOLON IND. (CORÉE)
RENFORT DU POINT D'ATTACHE	W-420	D-P (ALLEMAGNE)
RENFORT DU BORD DE FUITE	MYLAR	D-P (ALLEMAGNE)
RENFORT CLOISONS	LTN-0.8 STICK	SPORTWARE CO. (CHINE)
FIL	SERAFIL 60	AMAN (ALLEMAGNE)

<b>SUSPENTAGE</b>	<b>MATÉRIAUX</b>	<b>FABRICANT</b>
CASCADES SUPÉRIEURES	PPSL - 120	LIROS GMHB (ALLEMAGNE)
CASCADES INTERMÉDIAIRES	PPSL - 120	LIROS GMHB (ALLEMAGNE)
CASCADES INTERMÉDIAIRES	PPSL - 200	LIROS GMHB (ALLEMAGNE)
CASCADES INTERMÉDIAIRES	TNL - 80	TEIJIM LIMITED (JAPON)
CASCADES INTERMÉDIAIRES	TNL - 140	TEIJIM LIMITED (JAPON)
CASCADES PRINCIPALES	TNL - 140	TEIJIM LIMITED (JAPON)
CASCADES PRINCIPALES	TNL - 220	TEIJIM LIMITED (JAPON)
CASCADES PRINCIPALES	TNL - 280	TEIJIM LIMITED (JAPON)
CASCADES PRINCIPALES	TNL - 400	TEIJIM LIMITED (JAPON)
CASCADES PRINCIPALES FREIN	TNL - 400	TEIJIM LIMITED (JAPON)
FIL	SERAFIL 60	AMAN (ALLEMAGNE)

<b>ÉLÉVATEURS</b>	<b>MATÉRIAUX</b>	<b>FABRICANT</b>
SANGLES	G-R 22	TECNI SANGLES (FRANCE)
INDICATEUR DE COULEUR	PAD	TECNI SANGLES (FRANCE)
FIL	V138	COATS (ROYAUME-UNI)
MAILLONS	MRI4	ANSUNG PRECISION (CORÉE)
POULIE	RF25109	RONSTAN (AUSTRALIE)

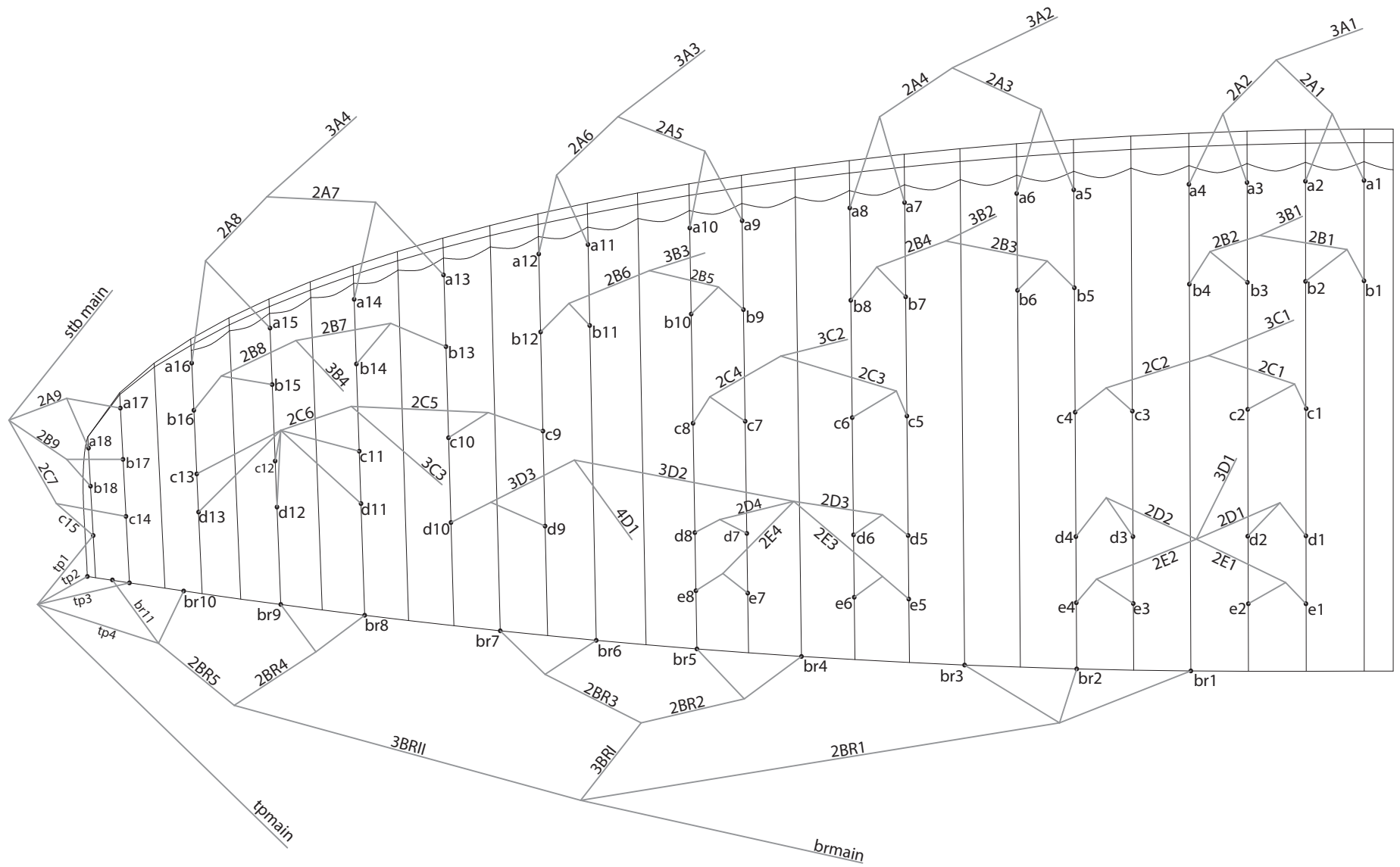

A A'		B	C	D
3A1	3A4	3B1	3C1	3D1
3A2		3B2	3C2	4D1
3A3		3B3	3C3	
		3B4		
		stb main		

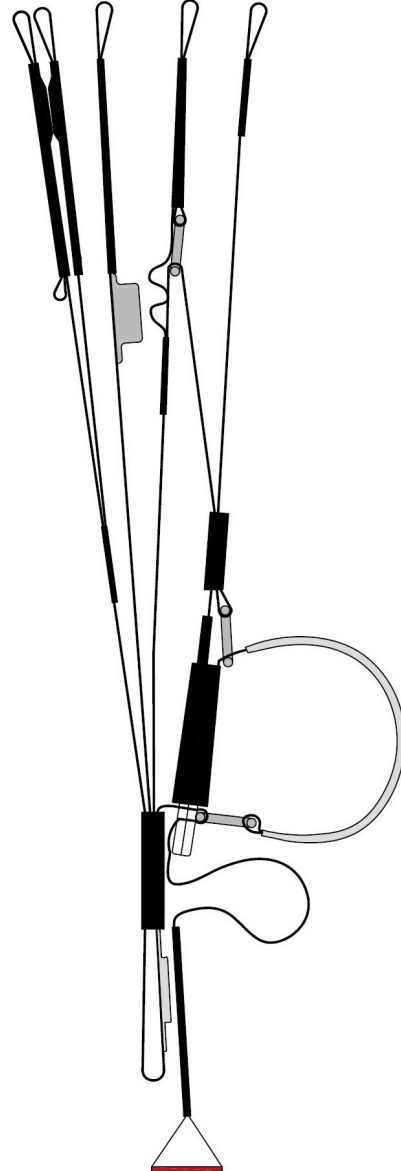

**DONNÉES TECHNIQUES DES COULEURS**

<b>ROCKET</b>	SB1	DRAGON RED	EXTRADOS	REF: 636
	SB2	DRAGON RED	INTRADOS	REF: 636
	SB3	BLACK	MOUSTACHE	REF: 102
	SB4	LIMA	LISERE	REF: 300
	SB5	LIMA	SECOND LISERET	REF: 300



<b>MINT</b>	SB1	LIMA	EXTRADOS	REF: 300
	SB2	LIMA	INTRADOS	REF: 300
	SB3	WHITE	MOUSTACHE	REF: 001
	SB4	ROYAL BLUE	LISERE	REF: 317
	SB5	ROYAL BLUE	SECOND LISERET	REF: 317

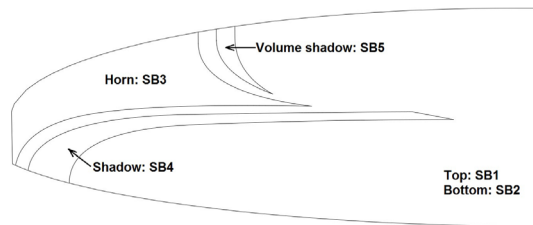

## NIVEAU D'UTILISATION

### R-BUS

37		40	
P.T.V.	kg/m <sup>2</sup>	P.T.V.	kg/m <sup>2</sup>
150	= 4,05	210	= 5,25
170	= 4,59	230	= 5,75
190	= 5,14	250	= 6,25
210	= 5,68	270	= 6,75
230	= 6,22	290	= 7,25
250	= 6,76	310	= 7,75
270	= 7,30	330	= 8,25
290	= 7,84	350	= 8,75
310	= 8,38	370	= 9,25
330	= 8,92	390	= 9,75
350	= 9,46	410	= 10,25
370	= 10,00	430	= 10,75
390	= 10,54	450	= 11,25
410	= 11,08	470	= 11,75
430	= 11,62	490	= 12,25
450	= 12,16	500	= 12,50
470	= 12,70		
490	= 13,24		
500	= 13,51		

**DONNÉES SUSPENTES**

**R-BUS 37**

REF.	MAT.	kg	COLOUR	m/m	REF.	MAT.	kg	COLOUR	m/m	REF.	MAT.	kg	COLOUR	m/m	REF.	MAT.	kg	COLOUR	m/m	REF.	MAT.	kg	COLOUR	m/m					
A					B					C					D					E					BRAKE				
a1	PPSL	120	YELLOW	569	b1	PPSL	120	BLUE	563	c1	PPSL	120	BLUE	475	d1	PPSL	120	BLUE	481	e1	PPSL	120	BLUE	510	br1	PPSL	120	RED	2013
a2	PPSL	120	YELLOW	504	b2	PPSL	120	BLUE	497	c2	PPSL	120	BLUE	400	d2	PPSL	120	BLUE	398	e2	PPSL	120	BLUE	434	br2	PPSL	120	RED	1707
a3	PPSL	120	YELLOW	518	b3	PPSL	120	BLUE	510	c3	PPSL	120	BLUE	400	d3	PPSL	120	BLUE	397	e3	PPSL	120	BLUE	433	br3	PPSL	120	RED	1611
a4	PPSL	120	YELLOW	560	b4	PPSL	120	BLUE	556	c4	PPSL	120	BLUE	466	d4	PPSL	120	BLUE	472	e4	PPSL	120	BLUE	500	br4	PPSL	120	RED	1072
a5	PPSL	120	YELLOW	554	b5	PPSL	120	BLUE	548	c5	PPSL	120	BLUE	441	d5	PPSL	120	BLUE	453	e5	PPSL	120	BLUE	481	br5	PPSL	120	RED	948
a6	PPSL	120	YELLOW	490	b6	PPSL	120	BLUE	484	c6	PPSL	120	BLUE	389	d6	PPSL	120	BLUE	367	e6	PPSL	120	BLUE	398	br6	PPSL	120	RED	915
a7	PPSL	120	YELLOW	484	b7	PPSL	120	BLUE	476	c7	PPSL	120	BLUE	356	d7	PPSL	120	BLUE	375	e7	PPSL	120	BLUE	408	br7	PPSL	120	RED	971
a8	PPSL	120	YELLOW	529	b8	PPSL	120	BLUE	525	c8	PPSL	120	BLUE	422	d8	PPSL	120	BLUE	422	e8	PPSL	120	BLUE	445	br8	PPSL	120	RED	847
a9	PPSL	120	YELLOW	503	b9	PPSL	120	BLUE	485	c9	PPSL	120	BLUE	1070	d9	PPSL	120	BLUE	764						br9	PPSL	120	RED	687
a10	PPSL	120	YELLOW	464	b10	PPSL	120	BLUE	476	c10	PPSL	120	BLUE	918	d10	PPSL	120	BLUE	823						br10	PPSL	120	RED	841
a11	PPSL	120	YELLOW	438	b11	PPSL	120	BLUE	448	c11	PPSL	120	BLUE	949	d11	PPSL	120	BLUE	1031						br11	PPSL	120	RED	711
a12	PPSL	120	YELLOW	468	b12	PPSL	120	BLUE	452	c12	PPSL	120	BLUE	887	d12	PPSL	120	BLUE	970										
a13	PPSL	120	YELLOW	1226	b13	PPSL	120	BLUE	1.132	c13	PPSL	120	BLUE	967	d13	PPSL	120	BLUE	1040										
a14	PPSL	120	YELLOW	1101	b14	PPSL	120	BLUE	1.017	c14	PPSL	120	BLUE	350															
a15	PPSL	120	YELLOW	1096	b15	PPSL	120	BLUE	1.011	c15	PPSL	120	BLUE	341															
a16	PPSL	120	YELLOW	1059	b16	PPSL	120	BLUE	987																				
a17	PPSL	120	YELLOW	509	b17	PPSL	120	BLUE	402																				
a18	PPSL	120	YELLOW	445	b18	PPSL	120	BLUE	374																				
2A1	PPSL	200	YELLOW	982	2B1	PPSL	200	BLUE	919	2C1	PPSL	200	BLUE	1202	2D1	TNL	140	BLUE	1041	2E1	PPSL	120	BLUE	1159	2BR1	PPSL	120	RED	4677
2A2	PPSL	200	YELLOW	955	2B2	PPSL	200	BLUE	894	2C2	PPSL	200	BLUE	1191	2D2	TNL	140	BLUE	1032	2E2	PPSL	120	BLUE	1149	2BR2	PPSL	120	RED	1133
2A3	PPSL	200	YELLOW	1574	2B3	PPSL	200	BLUE	1.475	2C3	TNL	140	BLUE	1074	2D3	TNL	80	BLUE	1022	2E3	PPSL	120	BLUE	1133	2BR3	PPSL	120	RED	1127
2A4	PPSL	200	YELLOW	1579	2B4	PPSL	200	BLUE	1488	2C4	TNL	140	BLUE	1.123	2D4	TNL	80	BLUE	968	2E4	PPSL	120	BLUE	1070	2BR4	PPSL	120	RED	1094
2A5	PPSL	200	YELLOW	1497	2B5	PPSL	200	BLUE	3480	2C5	TNL	140	BLUE	960											2BR5	PPSL	120	RED	689
2A6	PPSL	200	YELLOW	1508	2B6	PPSL	200	BLUE	3497	2C6	TNL	140	BLUE	868	3D2	TNL	140	BLUE	1550						3BRI	PPSL	120	RED	4026
2A7	PPSL	200	YELLOW	1145	2B7	PPSL	200	BLUE	1054	2C7	PPSL	120	RED	1113	3D3	TNL	140	BLUE	2179						3BRII	PPSL	120	RED	3973
2A8	PPSL	200	YELLOW	1056	2B8	PPSL	200	BLUE	978																				
2A9	PPSL	120	YELLOW	916	2B9	PPSL	120	RED	990																				
3A1	TNL	400	GREEN	6493	3B1	TNL	400	BLUE	6461	3C1	TNL	400	BLUE	6299	3D1	TNL	280	BLUE	6564	tp1	PPSL	120	RED	1.340					
3A2	TNL	400	GREEN	5888	3B2	TNL	400	BLUE	5901	3C2	TNL	220	BLUE	6433	4D1	TNL	280	BLUE	5106	tp2	PPSL	120	RED	1.260					
3A3	TNL	400	GREEN	5987	3B3	TNL	400	BLUE	3915	3C3	TNL	220	BLUE	5962						tp3	PPSL	120	RED	1.410	brmain	TNL	400	RED	2620
3A4	TNL	280	GREEN	5518	3B4	TNL	280	BLUE	5660											tp4	PPSL	120	RED	780					
					stb main	TNL	140	RED	5977											tpmain	TNL	280	RED	6230					knot point: 2420



**DONNÉES SUSPENTES**

**R-BUS 40**

REF.	MAT.	kg	COLOUR	m/m	REF.	MAT.	kg	COLOUR	m/m	REF.	MAT.	kg	COLOUR	m/m	REF.	MAT.	kg	COLOUR	m/m	REF.	MAT.	kg	COLOUR	m/m					
A					B					C					D					E					BRAKE				
a1	PPSL	120	YELLOW	591	b1	PPSL	120	BLUE	586	c1	PPSL	120	BLUE	493	d1	PPSL	120	BLUE	500	e1	PPSL	120	BLUE	530	br1	PPSL	120	RED	2093
a2	PPSL	120	YELLOW	525	b2	PPSL	120	BLUE	518	c2	PPSL	120	BLUE	416	d2	PPSL	120	BLUE	414	e2	PPSL	120	BLUE	452	br2	PPSL	120	RED	1775
a3	PPSL	120	YELLOW	538	b3	PPSL	120	BLUE	530	c3	PPSL	120	BLUE	416	d3	PPSL	120	BLUE	412	e3	PPSL	120	BLUE	450	br3	PPSL	120	RED	1676
a4	PPSL	120	YELLOW	582	b4	PPSL	120	BLUE	578	c4	PPSL	120	BLUE	484	d4	PPSL	120	BLUE	491	e4	PPSL	120	BLUE	520	br4	PPSL	120	RED	1115
a5	PPSL	120	YELLOW	576	b5	PPSL	120	BLUE	569	c5	PPSL	120	BLUE	459	d5	PPSL	120	BLUE	471	e5	PPSL	120	BLUE	500	br5	PPSL	120	RED	987
a6	PPSL	120	YELLOW	510	b6	PPSL	120	BLUE	504	c6	PPSL	120	BLUE	405	d6	PPSL	120	BLUE	382	e6	PPSL	120	BLUE	415	br6	PPSL	120	RED	951
a7	PPSL	120	YELLOW	503	b7	PPSL	120	BLUE	494	c7	PPSL	120	BLUE	370	d7	PPSL	120	BLUE	390	e7	PPSL	120	BLUE	424	br7	PPSL	120	RED	1010
a8	PPSL	120	YELLOW	550	b8	PPSL	120	BLUE	546	c8	PPSL	120	BLUE	439	d8	PPSL	120	BLUE	439	e8	PPSL	120	BLUE	462	br8	PPSL	120	RED	880
a9	PPSL	120	YELLOW	523	b9	PPSL	120	BLUE	504	c9	PPSL	120	BLUE	1113	d9	PPSL	120	BLUE	794						br9	PPSL	120	RED	715
a10	PPSL	120	YELLOW	482	b10	PPSL	120	BLUE	495	c10	PPSL	120	BLUE	955	d10	PPSL	120	BLUE	856						br10	PPSL	120	RED	874
a11	PPSL	120	YELLOW	456	b11	PPSL	120	BLUE	465	c11	PPSL	120	BLUE	987	d11	PPSL	120	BLUE	1072						br11	PPSL	120	RED	739
a12	PPSL	120	YELLOW	487	b12	PPSL	120	BLUE	471	c12	PPSL	120	BLUE	922	d12	PPSL	120	BLUE	1009										
a13	PPSL	120	YELLOW	1275	b13	PPSL	120	BLUE	1.177	c13	PPSL	120	BLUE	1006	d13	PPSL	120	BLUE	1082										
a14	PPSL	120	YELLOW	1145	b14	PPSL	120	BLUE	1.057	c14	PPSL	120	BLUE	364															
a15	PPSL	120	YELLOW	1140	b15	PPSL	120	BLUE	1.052	c15	PPSL	120	BLUE	355															
a16	PPSL	120	YELLOW	1102	b16	PPSL	120	BLUE	1.027																				
a17	PPSL	120	YELLOW	529	b17	PPSL	120	BLUE	418																				
a18	PPSL	120	YELLOW	462	b18	PPSL	120	BLUE	389																				
2A1	PPSL	200	YELLOW	1020	2B1	PPSL	200	BLUE	955	2C1	PPSL	200	BLUE	1249	2D1	TNL	140	BLUE	1081	2E1	PPSL	120	BLUE	1204	2BR1	PPSL	120	RED	4860
2A2	PPSL	200	YELLOW	994	2B2	PPSL	200	BLUE	930	2C2	PPSL	200	BLUE	1239	2D2	TNL	140	BLUE	1074	2E2	PPSL	120	BLUE	1196	2BR2	PPSL	120	RED	1178
2A3	PPSL	200	YELLOW	1636	2B3	PPSL	200	BLUE	1.533	2C3	TNL	140	BLUE	1116	2D3	TNL	80	BLUE	1062	2E3	PPSL	120	BLUE	1177	2BR3	PPSL	120	RED	1173
2A4	PPSL	200	YELLOW	1642	2B4	PPSL	200	BLUE	1549	2C4	TNL	140	BLUE	1.168	2D4	TNL	80	BLUE	1007	2E4	PPSL	120	BLUE	1113	2BR4	PPSL	120	RED	1137
2A5	PPSL	200	YELLOW	1555	2B5	PPSL	200	BLUE	3629	2C5	TNL	140	BLUE	998											2BR5	PPSL	120	RED	717
2A6	PPSL	200	YELLOW	1568	2B6	PPSL	200	BLUE	3647	2C6	TNL	140	BLUE	903	3D2	TNL	140	BLUE	1610						3BRI	PPSL	120	RED	4186
2A7	PPSL	200	YELLOW	1190	2B7	PPSL	200	BLUE	1096	2C7	PPSL	120	RED	1157	3D3	TNL	140	BLUE	2266						3BRII	PPSL	120	RED	4135
2A8	PPSL	200	YELLOW	1098	2B8	PPSL	200	BLUE	1017																				
2A9	PPSL	120	YELLOW	952	2B9	PPSL	120	RED	1029																				
3A1	TNL	400	GREEN	6766	3B1	TNL	400	BLUE	6733	3C1	TNL	400	BLUE	6565	3D1	TNL	280	BLUE	6842	tp1	PPSL	120	RED	1.465					
3A2	TNL	400	GREEN	6140	3B2	TNL	400	BLUE	6154	3C2	TNL	220	BLUE	6708	4D1	TNL	280	BLUE	5331	tp2	PPSL	120	RED	1.325					
3A3	TNL	400	GREEN	6246	3B3	TNL	400	BLUE	4081	3C3	TNL	220	BLUE	6221						tp3	PPSL	120	RED	1.480	brmain	TNL	400	RED	2788
3A4	TNL	280	GREEN	5518	3B4	TNL	280	BLUE	5908											tp4	PPSL	120	RED	800					
					stb main	TNL	140	RED	6237											tpmain	TNL	280	RED	6490					knot point: 2588

NIVIUK R-BUS 37

LONGUEURS TOTALES m/m

	A	B	C	D	E	br Tip	br
1	8031	7930	7963	8075	8222	7798	9098
2	7966	7864	7888	7992	8146	7725	8792
3	7953	7852	7877	7982	8135	7874	8696
4	7995	7898	7943	8057	8202	8074	8634
5	8003	7911	7937	8117	8254		8510
6	7939	7847	7885	8031	8171		8471
7	7938	7852	7901	7985	8118		8527
8	7983	7901	7967	8032	8155		8317
9	7974	7867	7981	8038			8157
10	7935	7858	7829	8097			7906
11	7920	7847	7768	7850			7776
12	7950	7851	7706	7789			
13	7876	7833	7786	7859			
14	7751	7718	7430				
15	7657	7636	7421				
16	7620	7612					
17	7392	7359					
18	7328	7331					

LONGUEURS DES ÉLÉVATEURS m/m

	A	A'	B	C	D	
	350	350	350	350	350	NEUTRE
	350	350	350	402	455	TRIMS OUVERTS

NIVIUK R-BUS 40

LONGUEURS TOTALES m/m

	A	B	C	D	E	br Tip	br
1	8364	8261	8294	8412	8565	8182	9479
2	8298	8193	8217	8326	8487	8053	9161
3	8285	8180	8207	8317	8477	8208	9062
4	8329	8228	8275	8396	8547	8395	9000
5	8339	8243	8272	8460	8602		8872
6	8273	8178	8218	8371	8517		8831
7	8272	8184	8235	8324	8462		8890
8	8319	8236	8304	8373	8500		8673
9	8311	8201	8321	8380			8508
10	8270	8192	8163	8442			8247
11	8257	8180	8100	8185			8112
12	8288	8186	8035	8122			
13	8212	8168	8119	8195			
14	8082	8048	7748				
15	7985	7964	7739				
16	7947	7939					
17	7708	7674					
18	7641	7645					

LONGUEURS DES ÉLÉVATEURS m/m

	A	A'	B	C	D	
	350	350	350	350	350	NEUTRE
	350	350	350	402	455	TRIMS OUVERTS

**DONNÉES TECHNIQUES SUSPENTAGE**

**R-BUS**

CODE MATÉRIEL		PPSL	PPSL	TNL	TNL	TNL	TNL	TNL
CODE CHARGE		120	200	080	140	220	280	400
DIAMÈTRE EN m/m	Ø	1,15	1,42	1,1	1,4	1,6	1,8	2,3
MATÉRIEL AME		DYNEEMA	DYNEEMA	TECHNORA	TECHNORA	TECHNORA	TECHNORA	TECHNORA
MATÉRIEL GAINÉ		POLYESTER	POLYESTER	POLYESTER	POLYESTER	POLYESTER	POLYESTER	POLYESTER
POIDS MÉTRIQUE g/m	TOTAL	1	1,6	1,1	1,2	1,6	2,7	4
CHARGE DE RUPTURE	MINIMUM	120	200	80	140	220	280	460
	MAXIMUM	159	241	92	160	250	320	470
RÉSISTANCE APRÈS 5,000 CYCLES DE FLEXION	TEST EN	135	191	36,7	76,1	114,2	134,7	160,1
ALLONGEMENT A	5 dan en %			0,3	0,2	0,2	0,2	0,05
	10 dan en %	0,2	0,24	0,5	0,3	0,3	0,3	0,1
	15 dan en %			0,7	0,5	0,5	0,4	0,2
	20 dan en %			1	0,6	0,6	0,4	0,2
	25 dan en %			1,3	0,8	0,7	0,5	0,3
	30 dan en %	0,6	0,55	2,3	1,5	1,2	0,9	0,6
	75 dan en %			2,8	2,3	1,8	1,3	0,8
	100 dan en %				2,7	2,2	1,7	1,1
	125 dan en %				3,2	2,7	2	1,4
	150 dan en %					3	2,3	1,7
	175 dan en %					3,3	2,7	2
	200 dan en %					3,8	2,8	2,2
ALLONGEMENT A LA CHARGE DE RUPTURE %		2		3	3,4	4	4,1	4,6

## DONNÉES TECHNIQUES MAILLON

### DESCRIPTION

MAILLON	DELTA
REF.	MRI4
MATÉRIEL	STAINLESS STEEL
DIAMÈTRE	4,3 m/m
POIDS	12 g/piece

### DONNÉES TECHNIQUES

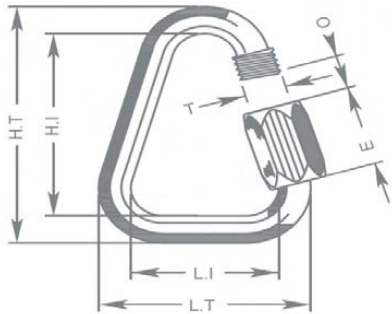

DIMENSIONS	m/m
L.T.	28
L.I.	20
H.T.	38
H.I.	30
O	4
E	11
T	4
CHARGE	kg
UTILE	150
RUPTURE	750

### MATÉRIEL

AISI 304 ACIER INOXYDABLE

STANDARD

UNE FERMETURE MANUELLE ET TOTALEMENT VISSÉE POUR GARANTIR UNE SÉCURITÉ MAXIMALE (LA SPIRALE EN MÉTAL NE DOIT PLUS APPARAÎTRE)

CONTRÔLE SYSTÉMATIQUE DES MAILLONS RAPIDES AVANT CHAQUE VOL

**DONNÉES TECHNIQUES FIL****CARACTÉRISTIQUES DU FIL DE COUTURE**

NOM	SERAFIL
N° DE REFERENCE	60
MATÉRIEL	POLYESTER
FINITION	SILK
DENSITÉ LINÉAIRE	NM 61 / 3 (DTEX 163 * 3)
CHARGE DE RUPTURE	3,000 CN
ALLONGEMENT	17,00%

**PROPRIÉTÉS SERAFIL**

SOLIDITÉ A LA LUMIÈRE ARTIFICIELLE	ISO 105 B02 > 5 - 6
SOLIDITÉ A LA SUEUR	ISO 105 E04 > 4
SOLIDITÉ AU LAVAGE	ISO 105 C04 > 3
SOLIDITÉ AU FROTTEMENT A SEC	ISO 105 X12 > 4
SOLIDITÉ AU LAVAGE EN SÈCHERESSE	ISO 105 D01 > 3 - 4

DEPERLANT	WR
-----------	----

**CARACTÉRISTIQUES DES ÉLÉVATEURS**

NOM	COATS BONDED C.F.P.
N° DE REFERENCE	V138
MATÉRIEL	POLYESTER
FINITION	SILK
CHARGE DE RUPTURE	9,5 kg
ALLONGEMENT	19%

**DONNÉES TECHNIQUES ÉLÉVATEURS****ÉLÉVATEURS**

RÉFÉRENCE	G-R 22
MATÉRIEL	POLYESTER
LARGEUR	22 m/m
ÉPAISSEUR	1,52 m/m
CHARGE DE RUPTURE	1,100 DAN
ALLONGEMENT	MAX. 15%
POIDS	25 g* L.M.
COULEUR	NOIR

**INDICATEUR DE COULEUR**

RÉFÉRENCE	IC-G 1-2
MATÉRIEL	POLYESTER
LARGEUR	70 m/m
ÉPAISSEUR	0,80 m/m
CHARGE DE RUPTURE	130 DN
ALLONGEMENT	35 %
POIDS	32 g* L.M.
COULEUR	VERT

**POINT D'ATTACHE**

RÉFÉRENCE	LKI - 10
MATÉRIEL	NYLON
LARGEUR	10 m/m
CHARGE DE RUPTURE	84 kg
ALLONGEMENT	30 %
POIDS	5,5 g/m
COULEUR	BLANC

