

DONNEES
TECHNIQUES
F-GRAVITY 2



DONNEES TECHNIQUES

FREE-GRAVITY 2			20	22	24
ALVEOLES	NOMBRE		50	50	50
	FERMES		8	8	8
	CAISSONS		25	25	25
A PLAT	SURFACE	M2	20	22	24
	ENVERGURE	M	10,3	10,8	11,28
	ALLONGEMENT		5,3	5,3	5,3
PROJETEE	SURFACE	M2	17,44	19,18	20,92
	ENVERGURE		8,56	8,97	9,37
	ALLONGEMENT		4,2	4,2	4,2
APLATISSEMENT		%	14	14	14
CORDE	MAXIMUM	M	2,36	2,48	2,59
	MINIMUM	M	0,52	0,55	0,57
	MOYENNE		1,94	2,03	2,12
SUSPENTES	TOTALES	M	317	333	362
	HAUTEUR	M	7,36	7,72	8,06
	NOMBRE		190	190	190
	REPARTITION		3/3/4/3	3/3/4/3	3/3/4/3
ELEVATEURS	NOMBRE	4	A/B/C/E	A/B/C/E	A/B/C/E
	TRIMS		NO	NO	NO
	ACCELERATEUR	m/m	150	150	150
POIDS TOTAL	MINIMUM	KG	60	80	100
EN VOL	MAXIMUM	KG	90	110	130
POIDS DE L'AILE		KG	5,5	5,8	6,1
HOMOLOGATION		EN	926-1	926-1	926-1

MATERIAUX

VOILERIE	MATERIAUX	FABRICANT
EXTRADOS	N30DMF-HD45	DOMINICO TEX CO (KOREA)
INTRADOS	N30DMF	DOMINICO TEX CO (KOREA)
PROFIL	30DFM	DOMINICO TEX CO (KOREA)
DIAGONALES	30DFM	DOMINICO TEX CO (KOREA)
POINT D'ATTACHE	LKI - 10	KOLON IND. (KOREA)
RENFORT DU POINT D'ATTACHE	W-420	D-P (GERMANY)
RENFORT DU POINT DE FUITE	MYLAR	D-P (GERMANY)
RENFORT CLOISONS	NYLON STICK	R.P.CHINA
FIL	SERAFIL 60	AMAN (GERMANY)

SUSPENTAGE	FABRIC CODE	SUPPLIER
CASCADES SUPERIEURES	TNL - 080	TEIJIM LIMITED (JAPAN)
CASCADES SUPERIEURES	TNL - 140	TEIJIM LIMITED (JAPAN)
CASCADES INTERMEDIAIRES	TNL - 080	TEIJIM LIMITED (JAPAN)
CASCADES INTERMEDIAIRES	TNL - 140	TEIJIM LIMITED (JAPAN)
CASCADES PRINCIPALES	TNL - 080	TEIJIM LIMITED (JAPAN)
CASCADES PRINCIPALES	TNL - 220	TEIJIM LIMITED (JAPAN)
CASCADES PRINCIPALES	TNL - 280	TEIJIM LIMITED (JAPAN)
CASCADES PRINCIPALES FREIN	TNL - 400	TEIJIM LIMITED (JAPAN)
FIL	SERAFIL 60	AMAN (GERMANY)

ELEVATEURS	MATERIAUX	FABRICANT
SANGLES	G-R 22	TECNI SANGLES (FRANCE)
INDICATEUR DE COULEUR	PAD	TECNI SANGLES (FRANCE)
FIL	V138	COATS (ENGLAND)
MAILLONS	MRI4	ANSUNG PRECISION (KOREA)
POULIE	PY - 1304-2	ANSUNG PRECISION (KOREA)

PLAN DE SUSPENTAGE

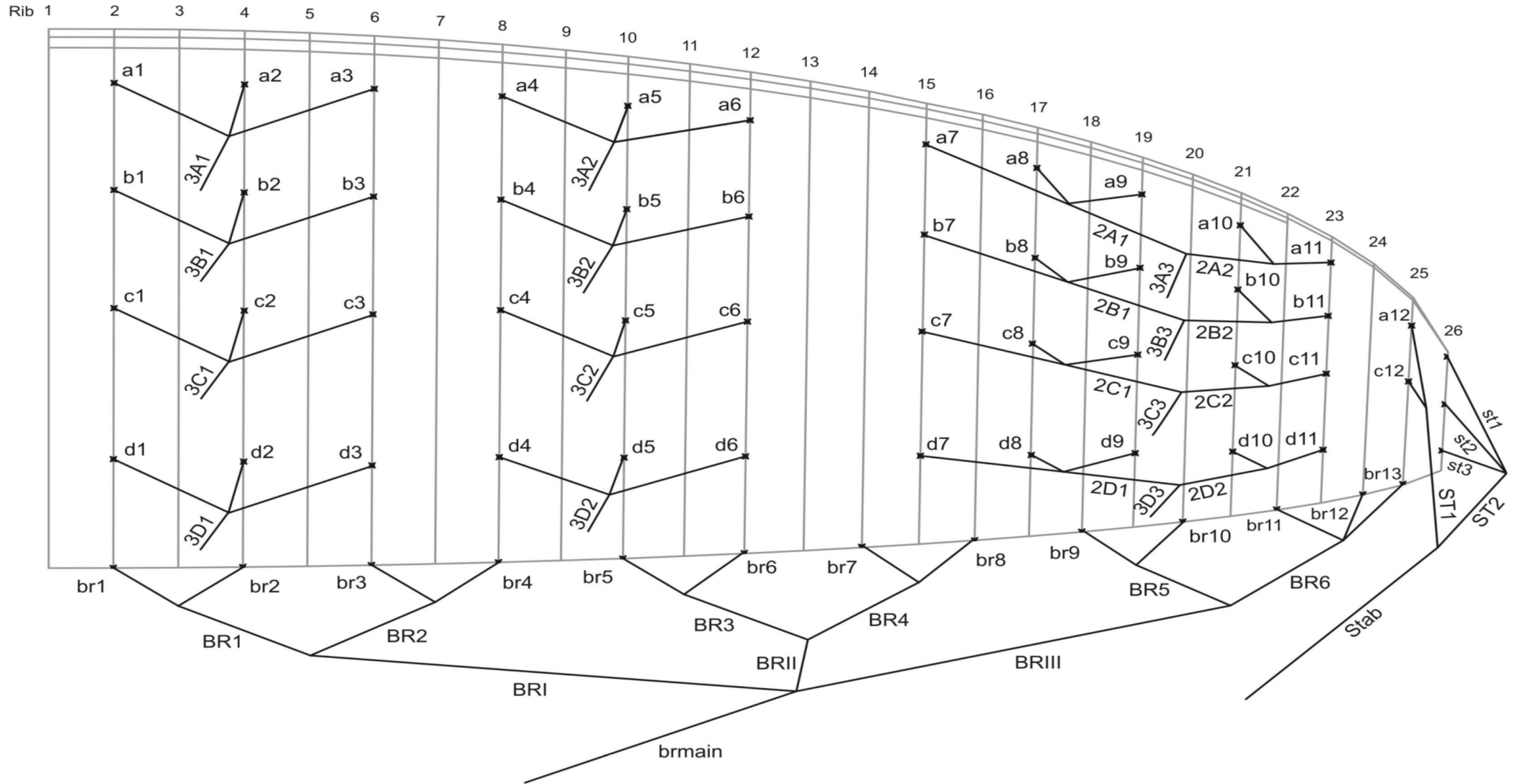



DONNEES TECHNIQUES DES COULEURS

JAMAICA	1	BLACK	EXTRADOS	REF: 102
	2	LIMA	MOUSTACHE	REF: NK375
	3	SUNFLOWER	LISERET	REF: 921
	4	BLACK	INTRADOS	REF: 102



LIMA	1	LIMA	EXTRADOS	REF: NK375
	2	GREY BLUE	MOUSTACHE	REF: NK5405
	3	WHITE	LISERET	REF: 001
	4	LIMA	INTRADOS	REF: NK375



DONNEES TECHNIQUES CHARGE ALAIRE

FREE-GRAVITY 2	20		22		24	
	P.T.V.	KG/M2	P.T.V.	KG/M2	P.T.V.	KG/M2
	70	= 3,50	90	= 4,09	110	= 4,58
	71	= 3,55	91	= 4,14	111	= 4,63
	72	= 3,60	92	= 4,18	112	= 4,67
	73	= 3,65	93	= 4,23	113	= 4,71
	74	= 3,70	94	= 4,27	114	= 4,75
	75	= 3,75	95	= 4,32	115	= 4,79
	76	= 3,80	96	= 4,36	116	= 4,83
	77	= 3,85	97	= 4,41	117	= 4,88
	78	= 3,90	98	= 4,45	118	= 4,92
	79	= 3,95	99	= 4,50	119	= 4,96
	80	= 4,00	100	= 4,55	120	= 5,00
	81	= 4,05	101	= 4,59	121	= 5,04
	82	= 4,10	102	= 4,64	122	= 5,08
	83	= 4,15	103	= 4,68	123	= 5,13
	84	= 4,20	104	= 4,73	124	= 5,17
	85	= 4,25	105	= 4,77	125	= 5,21
	86	= 4,30	106	= 4,82	126	= 5,25
	87	= 4,35	107	= 4,86	127	= 5,29
	88	= 4,40	108	= 4,91	128	= 5,33
	89	= 4,45	109	= 4,95	129	= 5,38
	90	= 4,50	110	= 5,00	130	= 5,42

DONNEES SUSPENTES

FREE-GRAVITY 2

20

REF.	CODE	m/m	REF.	CODE	m/m	REF.	CODE	m/m	REF.	CODE	m/m	REF.	CODE	m/m
A			B			C			D			BRAKE		
a1	TNL-140-green	1.836	b1	TNL-140-blue	1.818	c1	TNL-080-blue	1.577	d1	TNL-080-blue	1.415	br1	TNL-080-red	897
a2	TNL-140-green	1.761	b2	TNL-140-blue	1.743	c2	TNL-080-blue	1.492	d2	TNL-080-blue	1.320	br2	TNL-080-red	632
a3	TNL-140-green	1.767	b3	TNL-140-blue	1.751	c3	TNL-080-blue	1.510	d3	TNL-080-blue	1.348	br3	TNL-080-red	814
a4	TNL-140-green	1.765	b4	TNL-140-blue	1.746	c4	TNL-080-blue	1.518	d4	TNL-080-blue	1.367	br4	TNL-080-red	786
a5	TNL-140-green	1.668	b5	TNL-140-blue	1.652	c5	TNL-080-blue	1.414	d5	TNL-080-blue	1.250	br5	TNL-080-red	792
a6	TNL-140-green	1.654	b6	TNL-140-blue	1.642	c6	TNL-080-blue	1.412	d6	TNL-080-blue	1.253	br6	TNL-080-red	658
a7	TNL-140-green	1.555	b7	TNL-080-blue	1.534	c7	TNL-080-blue	1.340	d7	TNL-080-blue	1.213	br7	TNL-080-red	679
a8	TNL-080-green	1.438	b8	TNL-080-blue	1.425	c8	TNL-080-blue	1.210	d8	TNL-080-blue	1.065	br8	TNL-080-red	708
a9	TNL-080-green	1.398	b9	TNL-080-blue	1.390	c9	TNL-080-blue	1.169	d9	TNL-080-blue	1.021	br9	TNL-080-red	578
a10	TNL-080-green	764	b10	TNL-080-blue	755	c10	TNL-080-blue	526	d10	TNL-080-blue	458	br10	TNL-080-red	492
a11	TNL-080-green	758	b11	TNL-080-blue	749	c11	TNL-080-blue	558	d11	TNL-080-blue	497	br11	TNL-080-red	546
a12	TNL-080-green	830				c12	TNL-080-blue	835	st3	TNL-080-red	1.279	br12	TNL-080-red	514
st1	TNL-080-red	1.224				st2	TNL-080-red	1.234				br13	TNL-080-red	548
2A1	TNL-140-green	775	2B1	TNL-140-blue	762	2C1	TNL-140-blue	374	2D1	TNL-140-blue	353	BR1	TNL-080-red	1.258
2A2	TNL-140-green	1.354	2B2	TNL-140-blue	1.347	2C2	TNL-140-blue	996	2D2	TNL-140-blue	894	BR2	TNL-080-red	898
						ST1	TNL-080-red	823				BR3	TNL-080-red	1.017
						ST2	TNL-080-red	395				BR4	TNL-080-red	946
												BR5	TNL-080-red	964
												BR6	TNL-080-red	850
3A1	TNL-280-green	4.971	3B1	TNL-280-blue	4.926	3C1	TNL-280-blue	5.212	3D1	TNL-220-blue	5.506	BRI	TNL-140-red	3.615
3A2	TNL-280-green	4.924	3B2	TNL-280-blue	4.885	3C2	TNL-280-blue	5.156	3D2	TNL-220-blue	5.435	BRII	TNL-140-red	3.361
3A3	TNL-280-green	4.176	3B3	TNL-280-blue	4.165	3C3	TNL-220-blue	4.798	3D3	TNL-280-blue	5.059	BRIII	TNL-140-red	3.403
						stab	TNL-080-red	4.352				brmain	TNL-400-red	1.915
													Marque noeud:	1.715

DONNEES SUSPENTES

FREE-GRAVITY 2

22

REF.	CODE	m/m	REF.	CODE	m/m	REF.	CODE	m/m	REF.	CODE	m/m	REF.	CODE	m/m
A			B			C			D			BRAKE		
a1	TNL-140-green	1.925	b1	TNL-140-blue	1.906	c1	TNL-080-blue	1.654	d1	TNL-080-blue	1.483	br1	TNL-080-red	940
a2	TNL-140-green	1.847	b2	TNL-140-blue	1.828	c2	TNL-080-blue	1.565	d2	TNL-080-blue	1.385	br2	TNL-080-red	663
a3	TNL-140-green	1.854	b3	TNL-140-blue	1.837	c3	TNL-080-blue	1.585	d3	TNL-080-blue	1.415	br3	TNL-080-red	853
a4	TNL-140-green	1.851	b4	TNL-140-blue	1.831	c4	TNL-080-blue	1.592	d4	TNL-080-blue	1.433	br4	TNL-080-red	825
a5	TNL-140-green	1.750	b5	TNL-140-blue	1.733	c5	TNL-080-blue	1.483	d5	TNL-080-blue	1.311	br5	TNL-080-red	831
a6	TNL-140-green	1.736	b6	TNL-140-blue	1.723	c6	TNL-080-blue	1.481	d6	TNL-080-blue	1.315	br6	TNL-080-red	691
a7	TNL-140-green	1.631	b7	TNL-080-blue	1.609	c7	TNL-080-blue	1.405	d7	TNL-080-blue	1.272	br7	TNL-080-red	712
a8	TNL-080-green	1.509	b8	TNL-080-blue	1.495	c8	TNL-080-blue	1.269	d8	TNL-080-blue	1.117	br8	TNL-080-red	743
a9	TNL-080-green	1.466	b9	TNL-080-blue	1.458	c9	TNL-080-blue	1.227	d9	TNL-080-blue	1.071	br9	TNL-080-red	606
a10	TNL-080-green	801	b10	TNL-080-blue	791	c10	TNL-080-blue	552	d10	TNL-080-blue	480	br10	TNL-080-red	517
a11	TNL-080-green	795	b11	TNL-080-blue	786	c11	TNL-080-blue	585	d11	TNL-080-blue	521	br11	TNL-080-red	572
a12	TNL-080-green	870				c12	TNL-080-blue	876	st3	TNL-080-red	1.341	br12	TNL-080-red	539
st1	TNL-080-red	1.283				st2	TNL-080-red	1.294				br13	TNL-080-red	575
2A1	TNL-140-green	813	2B1	TNL-140-blue	799	2C1	TNL-140-blue	392	2D1	TNL-140-blue	370	BR1	TNL-080-red	1.319
2A2	TNL-140-green	1.420	2B2	TNL-140-blue	1.414	2C2	TNL-140-blue	1.046	2D2	TNL-140-blue	938	BR2	TNL-080-red	944
						ST1	TNL-080-red	863				BR3	TNL-080-red	1.067
						ST2	TNL-080-red	415				BR4	TNL-080-red	993
												BR5	TNL-080-red	1.010
												BR6	TNL-080-red	892
3A1	TNL-280-green	5.238	3B1	TNL-280-blue	5.191	3C1	TNL-280-blue	5.491	3D1	TNL-220-blue	5.799	BRI	TNL-140-red	3.789
3A2	TNL-280-green	5.191	3B2	TNL-280-blue	5.150	3C2	TNL-280-blue	5.434	3D2	TNL-220-blue	5.727	BRII	TNL-140-red	3.526
3A3	TNL-280-green	4.397	3B3	TNL-280-blue	4.391	3C3	TNL-280-blue	5.062	3D3	TNL-280-blue	5.335	BRIII	TNL-140-red	3.574
						stab	TNL-080-red	4.595				brmain	TNL-400-red	2.025
													Marque noeud:	1.825

DONNEES SUSPENTES

FREE-GRAVITY 2

24

REF.	CODE	m/m	REF.	CODE	m/m	REF.	CODE	m/m	REF.	CODE	m/m	REF.	CODE	m/m
A			B			C			D			BRAKE		
a1	TNL-140-green	2.009	b1	TNL-140-blue	1.990	c1	TNL-080-blue	1.726	d1	TNL-080-blue	1.548	br1	TNL-080-red	981
a2	TNL-140-green	1.929	b2	TNL-140-blue	1.910	c2	TNL-080-blue	1.635	d2	TNL-080-blue	1.447	br2	TNL-080-red	693
a3	TNL-140-green	1.938	b3	TNL-140-blue	1.920	c3	TNL-080-blue	1.657	d3	TNL-080-blue	1.479	br3	TNL-080-red	890
a4	TNL-140-green	1.933	b4	TNL-140-blue	1.912	c4	TNL-080-blue	1.662	d4	TNL-080-blue	1.496	br4	TNL-080-red	862
a5	TNL-140-green	1.828	b5	TNL-140-blue	1.811	c5	TNL-080-blue	1.549	d5	TNL-080-blue	1.369	br5	TNL-080-red	868
a6	TNL-140-green	1.814	b6	TNL-140-blue	1.800	c6	TNL-080-blue	1.548	d6	TNL-080-blue	1.374	br6	TNL-080-red	722
a7	TNL-140-green	1.703	b7	TNL-080-blue	1.680	c7	TNL-080-blue	1.468	d7	TNL-080-blue	1.329	br7	TNL-080-red	743
a8	TNL-080-green	1.576	b8	TNL-080-blue	1.561	c8	TNL-080-blue	1.326	d8	TNL-080-blue	1.167	br8	TNL-080-red	776
a9	TNL-080-green	1.532	b9	TNL-080-blue	1.524	c9	TNL-080-blue	1.282	d9	TNL-080-blue	1.119	br9	TNL-080-red	633
a10	TNL-080-green	837	b10	TNL-080-blue	826	c10	TNL-080-blue	576	d10	TNL-080-blue	501	br10	TNL-080-red	540
a11	TNL-080-green	831	b11	TNL-080-blue	821	c11	TNL-080-blue	611	d11	TNL-080-blue	545	br11	TNL-080-red	597
a12	TNL-080-green	909				c12	TNL-080-blue	915	st3	TNL-080-red	1.401	br12	TNL-080-red	563
st1	TNL-080-red	1.340				st2	TNL-080-red	1.352				br13	TNL-080-red	601
2A1	TNL-140-green	849	2B1	TNL-140-blue	834	2C1	TNL-140-blue	409	2D1	TNL-140-blue	386	BR1	TNL-080-red	1.377
2A2	TNL-140-green	1.484	2B2	TNL-140-blue	1.477	2C2	TNL-140-blue	1.092	2D2	TNL-140-blue	980	BR2	TNL-080-red	988
						ST1	TNL-080-red	902				BR3	TNL-080-red	1.114
						ST2	TNL-080-red	434				BR4	TNL-080-red	1.039
												BR5	TNL-080-red	1.053
												BR6	TNL-080-red	931
3A1	TNL-280-green	5.493	3B1	TNL-280-blue	5.444	3C1	TNL-280-blue	5.757	3D1	TNL-220-blue	6.079	BRI	TNL-140-red	3.955
3A2	TNL-280-green	5.447	3B2	TNL-280-blue	5.404	3C2	TNL-280-blue	5.701	3D2	TNL-220-blue	6.007	BRII	TNL-140-red	3.685
3A3	TNL-280-green	4.620	3B3	TNL-280-blue	4.614	3C3	TNL-220-blue	5.314	3D3	TNL-280-blue	5.599	BRIII	TNL-140-red	3.737
						stab	TNL-080-red	4.828				brmain	TNL-400-red	2.130
													Marque noeud:	1.930

NIVIUK FREE-GRAVITY 2 20

LONGUEURS TOTALES m/m					
	A	B	C	D	br
1	6812	6749	6794	6926	7465
2	6737	6674	6709	6831	7200
3	6743	6682	6727	6859	7022
4	6694	6636	6679	6807	6994
5	6597	6542	6575	6690	6865
6	6583	6532	6573	6693	6731
7	6511	6466	6517	6630	6681
8	6394	6357	6387	6482	6710
9	6354	6322	6346	6438	6640
10	6299	6272	6325	6416	6554
11	6293	6266	6357	6455	6494
12	6010		6015		6462
13	5970		5980	6026	6496

LONGUEURS DES ELEVATEURS m/m					
	A	B	C	D	
	490	490	490	490	NEUTRE
	340	380	430	490	ACCELEREE

NIVIUK FREE-GRAVITY 2 22

LONGUEURS TOTALES m/m					
	A	B	C	D	br
1	7170	7100	7153	7290	7870
2	7086	7018	7062	7187	7590
3	7100	7030	7081	7220	7410
4	7045	6980	7031	7160	7380
5	6950	6880	6923	7044	7250
6	6935	6870	6920	7049	7110
7	6850	6800	6857	6986	7063
8	6727	6685	6720	6834	7090
9	6686	6650	6681	6785	7020
10	6631	6597	6662	6760	6930
11	6622	6590	6685	6795	6865
12	6335		6344		6835
13	6305		6310	6355	6868

LONGUEURS DES ELEVATEURS m/m					
	A	B	C	D	
	490	490	490	490	NEUTRE
	340	380	430	490	ACCELEREE

LONGUEURS TOTALES m/m					
	A	B	C	D	br
1	7507	7439	7488	7632	8243
2	7427	7355	7397	7525	7955
3	7436	7369	7419	7558	7763
4	7385	7321	7368	7508	7735
5	7280	7220	7255	7375	7597
6	7266	7209	7254	7386	7451
7	7177	7129	7190	7319	7397
8	7050	7010	7054	7157	7430
9	7006	6970	7010	7109	7353
10	6946	6918	6983	7085	7260
11	6940	6910	7022	7129	7195
12	6644		6650		7161
13	6607		6619	6668	7199

LONGUEURS DES ELEVATEURS m/m					
	A	B	C	D	
	490	490	490	490	NEUTRE
	340	380	430	490	ACCELEREE

DONNEES TECHNIQUES SUSPENTAGE

FREE-GRAVITY 2

CODE MATERIEL		TNL	TNL	TNL	TNL	TNL
CODE CHARGE		080	140	220	280	400
DIAMETRE EN m/m	ø	1,1	1,4	1,6	1,8	2,3
MATERIEL AME		Technora	Technora	Technora	Technora	Technora
MATERIEL GAINÉ		Polyester	Polyester	Polyester	Polyester	Polyester
POIDS METRIQUE G/M	TOTAL	1,1	1,96	2,35	2,7	4
CHARGE DE RUPTURE	MINIMUM	80	140	220	280	460
	MAXIMUM	92	160	250	320	470
RESISTANCE APRES						
5,000 CYCLES	TEST EN	36,7	76,1	114,2	134,7	160,1
DE FLEXION						
ALLONGEMENT A	5 daN en %	0,3	0,2	0,2	0,2	0,05
	10 daN en %	0,5	0,3	0,3	0,3	0,1
	15 daN en %	0,7	0,5	0,5	0,4	0,2
	20 daN en %	1	0,6	0,6	0,4	0,2
	25 daN en %	1,3	0,8	0,7	0,5	0,3
	30 daN en %	2,3	1,5	1,2	0,9	0,6
	75 daN en %	2,8	2,3	1,8	1,3	0,8
	100 daN en %		2,7	2,2	1,7	1,1
	125 daN en %		3,2	2,7	2	1,4
	150 daN en %			3	2,3	1,7
	175 daN en %			3,3	2,7	2
	200 daN en %			3,8	2,8	2,2
ALLONGEMENT CHARGE DE RUPTURE %		3	3,4	4	4,1	4,6

DONNEES TECHNIQUES MAILLON

DESCRIPTION

MAILLON	DELTA
CODE	MRI4
MATERIEL	ACIER INOXYDABLE
DIAMETRE	4,3 m/m
POIDS	12 G/PIECE

SPECIFICATIONS TECHNIQUES

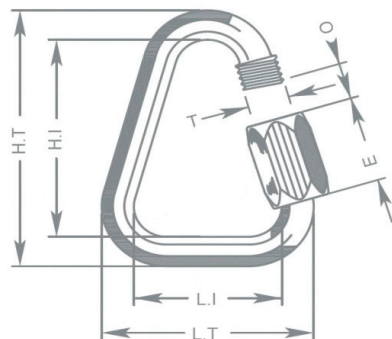

DIMENSIONS	m/m
L.T.	28
L.I.	20
H.T.	38
H.I.	30
O	4
E	11
T	4
CHARGE	KG
UTILE	150
RUPTURE	750

MATERIEL

AISI 304 ACIER INOXYDABLE

CONTROLE SYSTEMATIQUE DES MAILLONS RAPIDES AVANT CHAQUE VOL

DONNEES TECHNIQUES FIL

CARACTERISTIQUES DU FIL DE COUTURE

NOM	SERAFIL
N° DE REFERENCE	60
MATERIEL	POLYESTER
FINITION	SILK
DENSITE LINEAIRE	NM 61 / 3 (DTEX 163 * 3)
CHARGE DE RUPTURE	3,000 CN
ALLONGEMENT	17,00%

PROPRIETES SERAFIL

SOLIDITE A LA LUMIERE ARTIFICIELLE	ISO 105 B02 > 5 - 6
SOLIDITE A LA SUEUR	ISO 105 E04 > 4
SOLIDITE AU LAVAGE	ISO 105 C04 > 3
SOLIDITE AU FROTTEMENT A SEC	ISO 105 X12 > 4
SOLIDITE AU LAVAGE EN SECHERESSE	ISO 105 D01 > 3 - 4

DEPERLANT	WR
-----------	----

CARACTERISTIQUES DU FIL DES ELEVATEURS

NOM	COATS BONDED C.F.P.
N° DE REFERENCE	V138
MATERIEL	POLYESTER
FINITION	SILK
CHARGE DE RUPTURE	9,5 KG
ALLONGEMENT	19%

DONNEES TECHNIQUES SANGLES

ELEVATEURS

REFERENCE	G-R 22
MATERIEL	POLYESTER
LARGEUR	22 M/M
EPAISSEUR	1,52 M/M
CHARGE DE RUPTURE	1,100DAN
ALLONGEMENT	MAX. 15%
POIDS	25 G* L.M.
COULEUR	BLACK

INDICATEUR DE COULEUR

REFERENCE	IC-G 1-2
MATERIEL	POLYESTER
LARGEUR	70 M/M
EPAISSEUR	0,80 M/M
CHARGE DE RUPTURE	130 DN
ALLONGEMENT	35 %
POIDS	32 G * L.M.
COULEUR	GREEN

POINT D'ATTACHE

REFERENCE	LKI - 10
MATERIEL	NYLON
EPAISSEUR	10 M/M
CHARGE DE RUPTURE	84 KG
ALLONGEMENT	30 %
POIDS	5,5 G/M
COULEUR	WHITE

