

# HOOK 6

User manual &  
*Technical data*



**PIVIUK** BEYOND  
THE GLIDE

# Take the *next step*

---

## WELCOME

We welcome you to our team and thank you for the trust you have placed in us by choosing a Niviuk paraglider.

We would like you to share the enthusiasm with which we have created this paraglider and the importance and care with which we have developed the design and manufacture of this new model. All this, in order to be able to offer you the maximum pleasure in every flight under a Niviuk paraglider.

The HOOK 6 is an accessible and stable progression glider that will allow you to advance in all your flights and encourage you to experience new adventures.

We are confident you will enjoy flying this glider and will soon discover the meaning of our motto:

*“The importance of small details to make great things happen”.*

This is the user manual and we recommend you read it carefully.



## **USER MANUAL**

---

This manual provides you with the necessary information on the main characteristics of your new paraglider.

Whilst it provides information on the wing, it cannot be viewed as an instructional handbook and does not offer the training required to fly this type of paraglider. Training can only be undertaken at a certified paragliding school and each country has its own system of licensing.

Only the aeronautical authorities of respective countries can determine pilot competence.

The information in this manual is provided in order to warn you against adverse flying situations and potential dangers.

Equally, we would like to remind you that it is important to carefully read all the contents of your new HOOK 6 manual.

Misuse of this equipment could lead to severe injuries or death. The manufacturers and dealers cannot be held responsible for misuse of the paraglider. It is the responsibility of the pilot to ensure the equipment is used correctly.

# 01

<b>CHARACTERISTICS</b>	<b>5</b>
1.1 WHO IS IT DESIGNED FOR?	5
1.2 CERTIFICATION	5
1.3 IN-FLIGHT BEHAVIOR	5
1.4 TECHNOLOGIES, CONSTRUCTION, MATERIALS	5
1.5 ELEMENTS, COMPONENTS	6

# 02

<b>UNPACKING AND ASSEMBLY</b>	<b>7</b>
2.1 CHOOSING THE RIGHT LOCATION	7
2.2 PROCEDURE	7
2.3 CONNECTING THE HARNESS	7
2.4 HARNESS TYPE	7
2.5 SPEED-BAR	7
2.6 INSPECTION AND WING INFLATION ON THE GROUND	8
2.7 ADJUSTING THE BRAKES	8

# 03

<b>THE FIRST FLIGHT</b>	<b>8</b>
3.1 CHOOSING THE RIGHT LOCATION	8
3.2 PREPARATION	8
3.3 FLIGHT PLAN	8
3.4 PRE-FLIGHT CHECK	8
3.5 WING INFLATION, CONTROL AND TAKEOFF	9
3.6 LANDING	9
3.7 PACKING	9

# 04

<b>IN FLIGHT</b>	<b>9</b>
4.1 FLYING IN TURBULENCE	9
4.2 POSSIBLE CONFIGURATIONS	9
4.3 ACCELERATED FLIGHT	11
4.4 FLYING WITHOUT BRAKE LINES	11
4.5 LINE KNOT(S) IN FLIGHT	11

# 05

<b>LOSING ALTITUDE</b>	<b>11</b>
5.1 BIG EARS	11
5.2 B-LINE STALL	11
5.3 SPIRAL DIVE	12
5.4 SLOW DESCENT TECHNIQUE	12

# 06

<b>SPECIAL METHODS</b>	<b>12</b>
6.1 TOWING	12
6.2 ACROBATIC FLIGHT	12

# 07

<b>CARE AND MAINTENANCE</b>	<b>12</b>
7.1 MAINTENANCE	12
7.2 STORAGE	13
7.3 CHECKS AND INSPECTIONS	13
7.4 REPAIRS	13

# 08

<b>SAFETY AND RESPONSABILITY</b>	<b>14</b>
----------------------------------	-----------

# 09

<b>GUARANTEE</b>	<b>14</b>
------------------	-----------

# 10

<b>ANNEXES</b>	<b>16</b>
10.1 TECHNICAL SPECIFICATIONS	17
10.2 COLOURS	18
10.3 MATERIALS	19
10.4 LINE PLAN	20
10.5 RISER PLAN	21
10.6 LINE MEASUREMENTS BY SIZE	22
10.7 TOTAL LINE LENGTH	28
10.8 MINIMUM STRENGTH OF SUSPENSION LINES	30
10.9 MAILLON & PULLEY	31
10.10 CERTIFICATION	32

# 1. CHARACTERISTICS

## 1.1 WHO IS IT DESIGNED FOR?

The new HOOK 6 provides the perfect balance to progress in all your flights and it will encourage you to experience new adventures. The excellent qualities of the previous model have been optimised to offer more stability, control, comfort and performance.

It is a very intuitive, stable and safe glider, offering better performance and efficiency than the previous model. Ideal for progression, as well as trying out new flying disciplines. It features optimised handling to enhance the pilot's flying experience.

## 1.2 CERTIFICATION

The HOOK 6 has been submitted for the European EN and LTF certification. All certification tests were performed at the Swiss testing house Air Turquoise. All sizes passed the load, shock and flight tests.

The load test proved that the wing can withstand the stipulated 8G.

The shock test proved that the wing can resist 1000 daN of force.

The flight test resulted in the following certification of the HOOK 6 for all sizes (20, 22, 24, 26, 28 y 31):

EN B  
LTF B

We recommend that only pilots who are familiar with gliders of this certification or above fly this paraglider.

Only the aeronautical authorities of respective countries can determine pilot competence.

We recommend pilots read the flight test report carefully, especially the comments of the test pilot. The report contains all the necessary information on how the paraglider reacts during each of the tested manoeuvres.

It is important to note that different size wings will react differently during manoeuvres. Even within the same size, at maximum or minimum load, the behaviour and reactions of the wing may vary.

Description of EN B class wing characteristics:

- Paragliders with a high degree of passive safety and very forgiving flight characteristics. Gliders with high collapse resistance outside normal flight.

Description of the skills required by the pilot to fly an EN B wing:

- Designed for all pilots, including pilots at all levels of training and qualification.

For further information on the flight test and the corresponding certification, please see the final pages of this manual or see or visit the Downloads section at [www.niviuk.com](http://www.niviuk.com)

## 1.3 IN-FLIGHT BEHAVIOUR

Niviuk developed this wing by adopting very specific goals: to improve performance, excellent handling, to make flying easier for the pilot.

To increase performance while maintaining the highest level of safety. To ensure that the wing transmits the maximum feedback in an understandable and comfortable way so that the pilot can focus on piloting and enjoying the flight. And, with active piloting, take advantage of all favourable conditions.

In all aspects of flight, the wing is very solid and stable. The glide is smooth, even when fully accelerated. During glides, the wing maintains altitude and the wing remains stable. Improved turn precision means handling is less physical and provides better feedback. Inflating the wing is much easier and gentler, without overshooting.

Flying this wing is very intuitive, with clear and useful feedback about the airmass. It responds to the pilot's inputs effectively and even in thermic and turbulent conditions it remains stable and solid.

The HOOK 6 flies efficiently. It enters thermals with sufficient speed to centre in the lift and climbs progressively. The handling is progressive and effective for even more flying pleasure under an exciting wing of extraordinary quality.

It is lightweight; even lighter in flight and easy to pilot, with outstanding turbulence buffering and a surprising range of speed for incredible glides.

## 1.4 CONSTRUCTION, MATERIALS, TECHNOLOGIES

The HOOK 6 benefits from all the construction and assembly techniques used in our factory. It has all the current technology and accessories available to improve pilot comfort whilst increasing safety and performance. In the design of all Niviuk products the team aims to ensure development and continuous improvement. The technologies developed in recent years have allowed us to develop greater, better wings. It is in this context

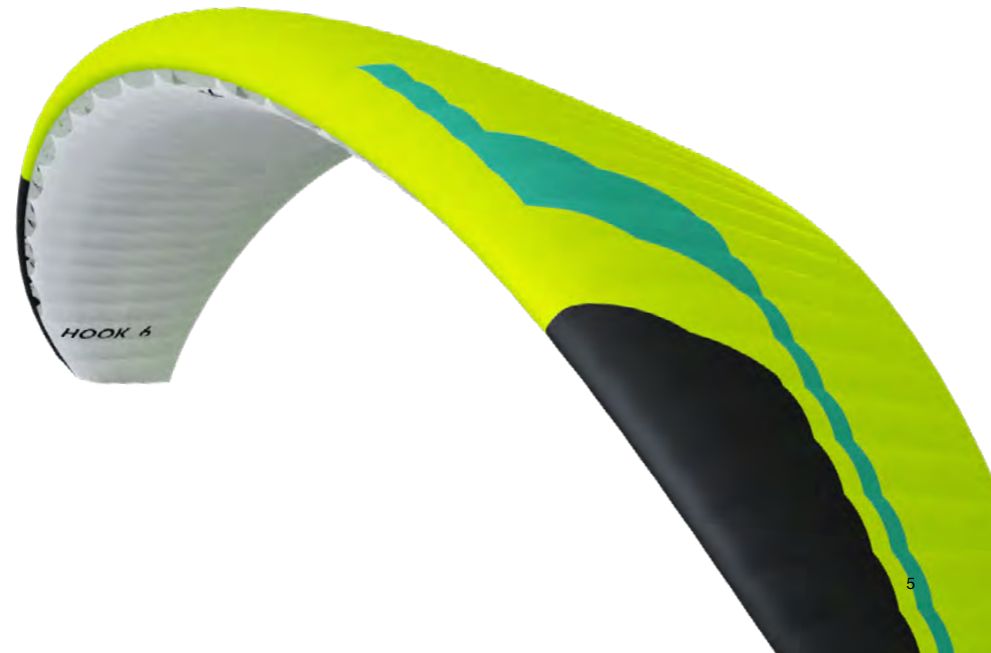

that we would like to introduce the technologies included in this new model:

**RAM Air Intake** - this system is characterised by the arrangement of the air inlets, to ensure optimal maintenance of internal pressure. Thanks to this design, we were able to reduce their size, while maintaining the same air flow at all angles to improve laminar flow. More consistency across the whole speed range and better performance without compromising on safety.

**Titanium Technology (TNT)** – a revolutionary technique using titanium. Using Nitinol in the internal construction provides a more uniform profile and reduces the weight to gain efficiency in flight. Nitinol provides the highest level of protection against deformation, heat or breaks.

**3D Pattern Cut Optimisation (3DP)** – the latest generation of wings require a new fabric panel pattern and cutting system. Creating separate panels for each of the sections at the front of the wing means the sail fabric is more taut and crease-free. During the cutting, the optimal orientation of the fabric section is selected, depending on its final location. If the fabric pattern is properly aligned with the axes of load, it suffers less deformation after repeated use, to the long-term benefit of the leading edge.

**3D Leading Edge (3DL)** - adding an extra reinforced seam to the leading edge helps to ensure more consistency and volume in the profile. This provides a more efficient 3D contour.

**Drag Reduction Structure (DRS)** - the trailing edge has been reinforced with small ribs in order to distribute the pressure more evenly. This results in excellent manoeuvrability and greater control and precision.

**Radial Sliced Diagonal (RSD)** - a reinvention of the wing's internal structure. This new design is based on individual diagonal panels arranged in radial form, which increase the efficiency of the internal structure considerably.

The use of these technologies is a big technological leap forward in building wings and a big improvement in flight comfort.

For the construction process of the HOOK 6 we use the same criteria, quality controls and manufacturing processes as in the rest of our range. From Olivier Nef's computer to fabric cutting, the operation does not allow for even a millimetre of error. The cutting of each wing component is performed by a rigorous, extremely meticulous, automated computer laser-cutting robotic arm.

This program also paints the guideline markers and numbers on each individual fabric piece, thus avoiding errors during this delicate process.

The jigsaw puzzle assembly is made easier using this method and optimises the operation while making the quality control more efficient. All Niviuk gliders go through an extremely thorough and detailed final inspection. The canopy is cut and assembled under strict quality control conditions facilitated by the automation of this process.

Every wing is individually checked with a final visual inspection.

The fabric used to manufacture the glider is light, resistant and durable. The fabric will not experience fading and is covered by our warranty.

The main and lower gallery lines are made from Technora with a polyester sheath, and the upper gallery lines are made from unsheathed Aramid.

The line diameter has been calculated depending on the workload and aims to achieve the required best performance with the least drag. The sheath protects the line cores from UV rays and abrasions.



The lines are semi-automatically cut to length and all the sewing is completed under the supervision of our specialists.

Every line is checked and measured once the final assembly is concluded.

Each glider is packed following specific maintenance instructions as recommended by the fabric manufacturer.

Niviuk gliders are made of premium materials that meet the requirements of performance, durability and certification that the current market demands.

Information about the various materials used to manufacture the wing can be viewed in the final pages of this manual.

## 1.5 ELEMENTS, COMPONENTS

The HOOK 6 is delivered with a series of accessories that will greatly assist you in the maintenance of your paraglider:

- An inner bag to protect the wing during storage and transport.
- An adjustable compression strap to compress the inner bag and reduce its volume.
- A repair kit with self-adhesive Ripstop tape and spare parts to protect the maillons.
- A Kargo bag. This bag is not included in the pack, but we recommend getting it. This bag is large enough to hold all equipment comfortably and with plenty of space.

## 2. UNPACKING AND ASSEMBLY

### 2.1 CHOOSING THE RIGHT LOCATION

We recommend unpacking and assembling the wing on a training hill or a flat clear area without too much wind and free of obstacles. It will help you to carry out all the recommended steps required to check and inflate the HOOK 6.

We recommend the whole installation procedure is supervised by a qualified professional instructor or official dealer. Only they can address any doubts in a safe and professional way.

### 2.2 PROCEDURE

Take the paraglider out of the rucksack, open and unfold it on the ground with the lines positioned on the undersurface, oriented in the direction of inflation. Check the condition of the fabric and the lines for defects. Check the maillons/IKS connecting the lines to the risers to make sure they are fully closed and tightened. Identify, and if necessary, untangle, the A, B and C-lines, the brake lines and corresponding risers. Make sure that there are no knots.

### 2.3 CONNECTING THE HARNESS

The HOOK 6 risers are colour-coded.

- Right: green
- Left: red

This colour-coding makes it easier to connect the wing to the correct side and helps prevent pre-flight errors.

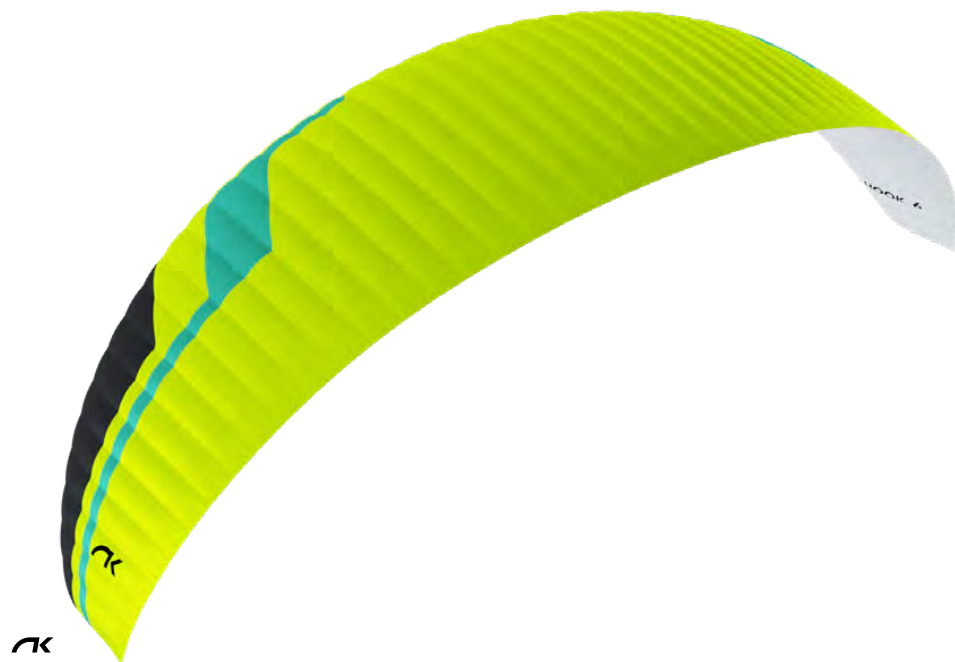

Correctly connect the risers to the attachment points so that the risers and lines are correctly ordered and free of twists. Check that the IKS and carabiners are properly fastened and securely locked.

### 2.4 HARNESS TYPE

The HOOK 6 can be flown with all current harness types. We recommend setting the chest strap to the distance specified in the certification report – this will vary depending on size. See the certification certificate.

Care should be taken with the chest strap setting, as the distance of the chest strap setting will affect the handling of the glider. If the chest strap is too wide, it allows greater feedback but this carries the risk of affecting the stability of the wing.

If the chest strap is set too tightly, the wing feels more solid, but there is a loss of feedback and a risk of twisting in the case of a violent asymmetric collapse.

### 2.5 SPEED-BAR

The speed-bar is a means of temporary acceleration by changing the flow over the profile. The speed system comes pre-installed on the risers and is not modifiable as it conforms to the measurements and limits stipulated in its certification.

The HOOK 6 includes a speed system with maximum travel depending on its size (see Full speed-bar).

The speed system is engaged when the pilot pushes the speed-bar (not included as standard with this glider model) with their feet (see 2.5.1 Speed system assembly)

The speed system uses an action/reaction system. Released, the speed-bar is set to neutral. When the bar is pushed using the feet, the wing accelerates. The speed can be regulated by varying the pressure on the bar. Once the pressure on the bar is released, the speed system returns to the neutral setting.

The speed system is efficient, sensitive and precise. The pilot can use the system whenever they want during the flight. In the neutral position the glider will fly at the standard speed and glide. Using full speed-bar, the wing will fly at maximum speed, but the glide will be adversely affected.

- Released speed-bar: the A, B, C-risers are aligned.
- Full speed-bar: the difference between the A - C-risers becomes:  
Size 20– 120 mm  
Sizes 22, 24, 26, 28, 31 – 145 mm

Please note!



The use of the speed system results in changes to the speed and reactions of the wing. For more information, please see the certification report.

#### 2.5.1 SPEED SYSTEM ASSEMBLY

The speed-bar consists of the bar that the pilot pushes with their feet, as well as the two cords that connect it to the speed system components on the risers. Once you have chosen the type of speed-bar you prefer, you must install it. Some considerations:

- You should use the type of speed-bar you consider appropriate, depending on the type of harness, personal preferences, etc.
- The speed-bar is detachable to facilitate its connection and / or disconnection to the risers as well as subsequent adjustment.
- To connect it to the harness, please follow the instructions of the harness manufacturer. The majority of harnesses have a speed system pre-installed.
- The standard connection of the speed-bar to the speed system is via Brummel hooks, where two slots in the hooks are interlocked, making their connection / disconnection easy. However, any connection system that is safe may be used.

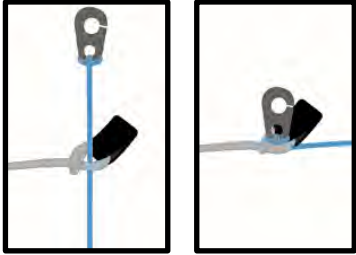

## 2.5.2 CHANGING THE RISER CORDS

In spite of the speed system having pulleys with bearings to reduce friction to a minimum, the frequency with which the speed-bar is used causes the cord to wear and you may need to replace them.

In all Niviuk gliders the speed system cords on the risers are completely removable and easily replaceable. You can use the Brummel hooks, not use them, remove them, use another type of connector, etc. It is even possible to fix the speed-bar cords directly to the speed system on the risers. This last option makes the connection / disconnection more laborious, but means the cord has maximum travel without obstructions or restrictions which is very useful for some models of harnesses.

## 2.6 INSPECTION AND WING INFLATION ON THE GROUND

After your gear has been thoroughly checked and the weather conditions deemed favourable for flying, inflate your HOOK 6 as many times as necessary to familiarise yourself with its behaviour. Inflating the HOOK 6 is easy and should not require a great deal of physical effort. Inflate the wing with a little pressure from the body using the harness. This may be assisted by using the A-lines. Do not pull on them; just accompany the natural rising movement of the wing. Once the wing is inflated to the overhead position, appropriate control with the brakes will be sufficient to hold it there.

## 2.7 ADJUSTING THE BRAKES

The length of the main brake lines are adjusted at the factory and conform to the length stipulated during certification. However, they can be changed to suit your flying style. It is advisable to fly with the original setting for a period of time to get used to the actual behaviour of the HOOK 6. In case it is necessary to modify the brake length, loosen the knot, slide the line through the brake handle to the desired point and re-tighten the knot firmly. Only qualified personnel should carry out this adjustment. You must ensure that the modification does not affect the trailing edge and slow the glider down without pilot input. Both brake lines should be symmetrical and the same length. We recommend using a clove hitch or bowline knot.

When changing the brake length, it is necessary to check that they do not engage when the speed-bar is used. When we accelerate, the glider rotates over the C-riser and the trailing edge elevates. It is important to check that the brake is adjusted to take into consideration this extra distance during acceleration. With this profile deformation there is a risk of generating turbulence and causing a frontal or asymmetric collapse.

## 3. THE FIRST FLIGHT

### 3.1 CHOOSING THE RIGHT LOCATION

For the first flight we recommend going to your usual flying area and that a qualified instructor is present and supervising the entire procedure.

### 3.2 PREPARATION

Repeat the procedures detailed in section 2 UNPACKING AND ASSEMBLY to prepare your equipment.

### 3.3 FLIGHT PLAN

Planning a flight before taking off to avoid possible problems later is always a good idea.

### 3.4 PRE-FLIGHT CHECK

Once ready, but before taking off, conduct another equipment inspection. Conduct a thorough visual check of your gear with the wing fully open, the lines untangled and properly laid out on the ground to ensure that all is in working order. Be certain the weather conditions are suited to your flying skill level.



### 3.5 WING INFLATION, CONTROL AND TAKEOFF

The HOOK 6 comes up easily, without requiring additional energy, and does not overfly you. It is a straight-forward exercise, leaving enough time for you to decide whether to accelerate and take off or not.

If the wind permits, we recommend a reverse launch, as this allows a better visual inspection of the wing during inflation. In “strong” winds, the HOOK 6 is especially easy to control using this launch technique. Winds of 25 to 30 km/h are considered strong for paragliding.

Correctly setting up the wing on the ground before takeoff is especially important. Choose an appropriate location facing the wind. Position the paraglider in a crescent configuration to facilitate inflation. A clean wing layout will ensure a trouble-free take off.

### 3.6 LANDING

The HOOK 6 lands excellently, it converts the wing speed into lift at your demand, allowing an enormous margin of error. Wrapping the brake lines around your hand to get greater braking efficiency is not necessary.

### 3.7 PACKING

The HOOK 6 has a complex leading edge, manufactured using a variety of different materials and it must be packed carefully. A correct folding method is very important to extend the useful life of your paraglider.

It should be concertina-packed, with the leading edge reinforcements flat and the flexible rods stacked one on top of the other. This method will keep the profile in its original shape and protect the integrity of the wing

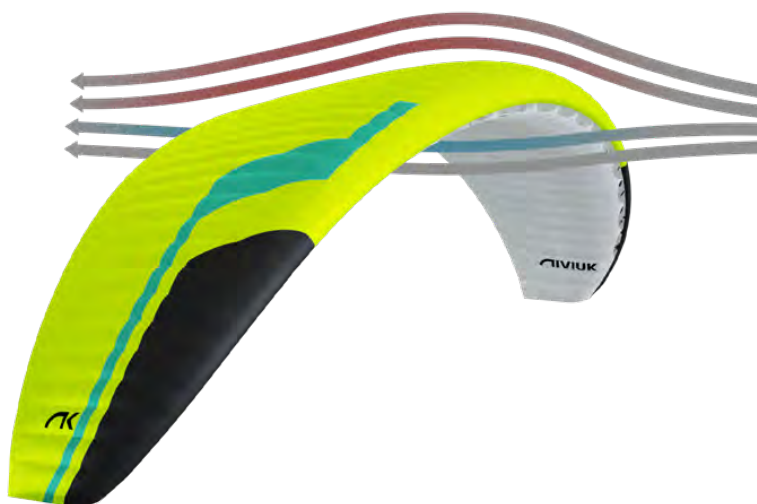

over time. Make sure the reinforcements are not bent or folded. It should not be folded too tightly to avoid damage to the cloth and/or lines.

At Niviuk we have designed the NKare Bag, a bag designed to assist you with rapid packing which helps maintain the integrity of the leading edge and its internal structures in perfect condition.

The NKare Bag guides you through the folding process, allowing you to concertina pack the wing with each rod on top of the other and then fold the wing as required. This folding system ensures that both the fabric and the reinforcements of the internal structure are kept in perfect condition.

## 4. IN FLIGHT

We recommend that you read the certification test report.

The report contains all the necessary information on the HOOK 6 reacts during each of the tested manoeuvres.

It is important to point out that the appropriate response to each adverse manoeuvre can vary from size to size; even within the same size at maximum or minimum load the behaviour and reactions of the wing may vary.

Having the knowledge that the testing house provides through the test report is fundamental to learning how to deal with possible situations.

To become familiar with the manoeuvres described below, we recommend practising within the auspices of a licensed training outfit.

### 4.1 FLYING IN TURBULENCE

The HOOK 6 has an excellent profile to deal with incidents; it is very stable in all conditions and has a high degree of passive safety, even in turbulent conditions.

All paragliders must be piloted for the prevailing conditions and the pilot is the ultimate safety factor.

We recommend active flying in turbulent conditions, always taking measures to maintain control of the wing, preventing it from collapsing and restoring the speed required by the wing after each correction.

Do not correct the glider (braking) for too long in case this provokes a stall. If you have to take corrective action, make the input then re-establish the correct flying speed.

### 4.2 POSSIBLE CONFIGURATIONS

To become familiar with the manoeuvres described below, we recommend practising within the environment of a licensed training outfit. You must adapt your use of the brakes depending on the wing-loading and avoid over-steering.

It is important to note that the type of reaction to a manoeuvre can vary from one size of wing to another, and even within the same size the behaviour and reactions may be different depending on the wing-loading.

In the test report, you will find all the necessary information on how to handle your new wing during each of

the tested manoeuvres. Having this information is crucial to know how to react during these manoeuvres in real flight, so you can deal with these situations as safely as possible.

### Asymmetric collapse

In spite of the HOOK 6's profile stability, strong turbulent air may cause the wing to collapse asymmetrically in very strong turbulence, especially if you do not fly actively and prevent the collapse. In this case the glider conveys a loss of pressure through the brake lines and the harness. To prevent the collapse from happening, pull the brake handle on the affected side of the wing. It will increase the incidence of the wing (angle of attack). If the collapse does happen, the HOOK 6 will not react violently, the turning tendency is gradual and easily controlled. Weight-shift toward the open, flying side (the opposite side of the collapse) to keep the wing flying straight, while applying light brake pressure to that side if necessary. Normally, the collapsed side of the wing should then recover and reopen by itself. If it does not, try to weight-shift towards the collapsed side. If this does not resolve the issue, pull the brake handle on the collapsed side decisively and quickly all the way (100%) down and release it back up immediately. You may have to repeat this action to provoke the re-opening of the collapsed glider side. Do not over-brake or slow down the flying side of the wing (control the turn). Once the collapsed side is open make sure you return to normal flying speed.

### Frontal collapse

Due to the HOOK 6's design, in normal flying conditions frontal collapses are unlikely to take place. The wing's profile has great buffering abilities when dealing with extreme incidence changes. A frontal collapse may occur in strong turbulent conditions, entering or exiting powerful thermals. Frontal collapses usually re-inflate without the glider turning, but a symmetrically applied quick braking action with a quick deep pump of both brakes will accelerate the re-inflation if necessary. Release the brake lines immediately to return to default glider air speed.

### Negative spin

A negative spin does not conform to the HOOK 6's normal flight behaviour. Certain circumstances however, may provoke a negative spin (such as trying to turn when flying at very low air speed whilst applying a lot of brake). It is not easy to give any specific recommendation about this situation other than quickly restoring the wing's default air speed and angle of attack by progressively reducing the tension on the brake lines. The normal wing reaction will be to have a lateral surge on the re-accelerated side with a rotation not greater than 360° before returning to default air speed and a straight flight path trajectory.

### Parachutal stall

The possibility of entering or remaining in a parachutal stall have been eliminated from the HOOK 6. A parachutal stall is virtually impossible with this wing. If it did enter into a parachutal stall, the wing loses forward motion, becomes unstable and there is a lack of pressure on the brake lines, although the canopy appears to be fully inflated. To regain normal air speed, release brake line tension symmetrically and manually push on the A-lines or weight-shift your body to any side WITHOUT PULLING ON THE BRAKE LINES.

### Deep Stall

The possibility of the HOOK 6 stalling during normal flight is very unlikely. It could only happen if you are flying at a very low air speed, whilst over-steering or performing dangerous manoeuvres in turbulent air.

To provoke a deep stall, the wing has to be slowed down to its minimum air speed by symmetrically pulling the brake lines all the way (100%) down until the stall point is reached and held there. The glider will first pitch rearward and then reposition itself overhead, rocking slightly, depending on how the manoeuvre is done.

When entering a stall, remain clear-headed and ease off the brake lines until reaching the half-way point of the total brake travel. The wing will then surge violently forward and could reach a point below you. It is most important to maintain brake pressure until the glider has returned to its default overhead flying position.

To resume normal flight conditions, progressively and symmetrically release the brake line tension to regain air speed. When the wing reaches the overhead position, the brakes must be fully released. The wing will then surge



forward to regain full air speed. Do not brake excessively at this moment as the wing needs to accelerate to pull away from the stall configuration. If you have to control a possible frontal collapse, briefly pull both brake handles down to bring the wing back up and release them immediately while the glider is still in transition to reposition itself overhead.

### Cravat

A cravat may happen after an asymmetric collapse, when the end of the wing is trapped between the lines. Depending on the nature of the tangle, this situation could rapidly cause the wing to spin. The corrective manoeuvres to use are the same as those applied in case of an asymmetric collapse: control the turn/spin by applying tension on the opposite brake and weight shift opposite to the turn. Then locate the 3STI stabilo line (attached to the wing tip) trapped between the other lines. This line has a different colour and is located on the outside position of the B-riser.

Pull this line until it is taut. This action will help to release the cravat. If ineffective, fly down to the nearest possible landing spot, controlling the direction with both weight-shift and the use of the brake opposite to the tangled side. Be cautious when attempting to undo a tangle while flying near terrain or other paragliders; it may not be possible to continue on the intended flight path.

### Over-controlling

Most flying problems are caused by wrong pilot input, which then escalates into a cascade of unwanted and unpredicted incidents. We should note that the wrong inputs can lead to loss of control of the glider. The HOOK 6 was designed to recover by itself in most cases. Do not try to over-correct it!

Generally speaking, the reactions of the wing, which are caused by too much input, are due to the length of time the pilot continues to over-control the wing. You have to allow the glider to re-establish normal flying speed and attitude after any type of incident.

### 4.3 ACCELERATED FLIGHT

The HOOK 6's profile was designed for stable flight throughout its entire speed range. The speed-bar can be used in strong winds or significant sink.

When accelerating the wing, the profile becomes more sensitive to turbulence and closer to a possible frontal collapse. If a loss in internal wing pressure is felt, tension on the speed-bar should be reduced to a minimum and a slight pull on the brake lines is recommended to increase the wing's incidence angle. Remember to re-establish the air speed after correcting the angle of attack.

It is NOT recommended to accelerate near obstacles or in very turbulent conditions. If necessary, constantly adjust the movements and pressure on the speed-bar whilst doing the same to the brake lines. This balance is considered to be 'active piloting'.

### 4.4 FLYING WITHOUT BRAKE LINES

If, for any reason at all, the HOOK 6's brake lines become disabled in flight, it will become necessary to pilot the wing with the C-risers and weight shifting until landing. These risers steer easily because are not under significant tension. You will have to be careful and not handle them too heavily in case this causes a stall or negative spin. The wing must be flown at full speed (not accelerated) during the landing approach, and the C-risers will have to be pulled symmetrically all the way down shortly before contact with the ground. This braking method is not as effective as using the brake lines, and hence the wing will land with a higher ground speed.

### 4.5 LINE KNOT(S) IN FLIGHT

The best way to avoid knots and tangles is to thoroughly inspect the lines as part of a systematic pre-flight check. If a knot is spotted during the take off phase, immediately abort the launch sequence and stop.

If inadvertently taking off with a knotted line, the glider drift will need to be compensated by weight-shifting to the opposite side and applying a slight brake pull to that side. Gently pull the brake line to see if the knot can be undone or try to locate the problem line. Try pulling it to see if the knot can be undone. Beware of trying to clear a knotted line or untangle a line in flight when close to the terrain. If the knot is too tight and cannot be undone, carefully and safely fly to the nearest landing zone. Be careful: do not pull too hard on the brake handles because there will be an increased risk of stalling the wing or entering a negative spin. Before attempting to clear a knot, make sure there are no other pilots flying in the vicinity.

## 5. LOSING ALTITUDE

Knowledge of different descent techniques could become vital in certain situations. The most suitable descent method will depend on the particular situation.

To become familiar with the manoeuvres described below, we recommend practising within the environment of a licensed training outfit.

### 5.1 BIG EARS

The "Big ears" is a moderate descent technique, able to increase the sink rate to  $-3$  or  $-4$  m/s and reduces the ground speed by 3 to 5 km/h. The angle of attack and effective wing-loading will also increase due to the smaller surface area of the wing.

To perform the 'Big ears' manoeuvre, take the A' line on each A-riser (the 4A3 line on the HOOK 6) and simultaneously, smoothly pull them outward and downward. The wingtips will fold in.

To re-establish forward speed and the correct angle of attack, accelerate once the ears are pulled.

Keep the ears pulled in until you have lost the desired altitude.

Let go of the lines to re-inflate the tips automatically. If they do not, try progressively pulling one brake then the other. Asymmetric reopening is recommended in order to avoid compromising the angle of attack, particularly flying near the ground or in turbulent conditions.

### 5.2 B-LINE STALL

When carrying out this manoeuvre, the wing stops flying, loses all horizontal speed and the pilot is no longer in control of the paraglider.

The airflow over the profile is interrupted and the wing enters a situation similar to parachuting.

To enter this manoeuvre, the B-risers are gripped below the maillons and symmetrically pulled down together (approx. 20-30 cm) and maintained in that position.

Initiating the maneuver is physically demanding because it can take some strength to pull the risers down until the wing is deformed. After this, the physical effort is less. Continue to hold the risers in position.

Once the wing is deformed, its horizontal speed will drop to 0 km/h; vertical descending speed increases to  $-6$  to  $-8$  m/s, depending on the conditions and how the manoeuvre is performed.

To exit the manoeuvre, simultaneously release both risers. The wing will then slightly surge forward and automatically return to normal flight. It is better to let go of the lines quickly rather than slowly.

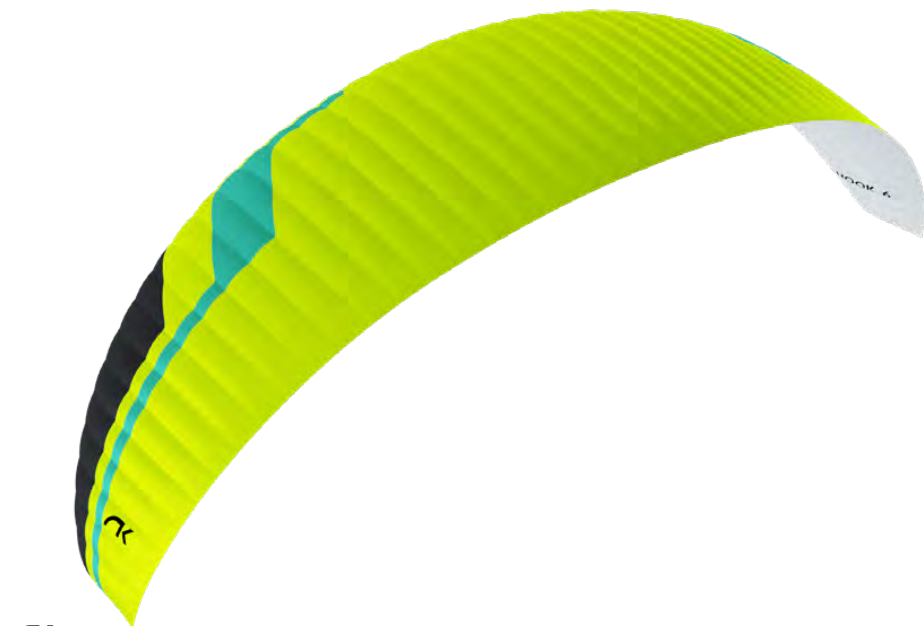

This is an easy descent technique to perform, but remember that the wing will stop flying, will lose all forward horizontal speed, and its reactions will change markedly when compared to a normal flight configuration.

### 5.3 SPIRAL DIVE

This is a more effective way to rapidly lose altitude. Beware that the wing will experience and be subjected to a tremendous amount of descending and rotating speed (g-force), which can cause a loss of orientation and consciousness (blackout). This manoeuvre must therefore be done gradually to increase one's capacity to resist the g-force exerted on the body. With practise, you will fully appreciate and understand it. Only practise this manoeuvre at high altitude and with enough ground clearance.

To start the manoeuvre, first weight shift and pull the brake handle located on the inner side of the turn. The intensity of the turn can be controlled by braking slightly using the outer brake handle.

A paraglider flying at its maximum rotating speed can reach  $-20$  m/s, or the equivalent of a 70 km/h vertical descent, and will stabilise in a spiral dive from 15m/s onwards.

Good enough reasons to familiarise yourself with the manoeuvre and understand how to exit it.

To exit this manoeuvre, the inner brake handle (down side of the turn) must progressively be relaxed while momentarily applying tension to the outer brake handle opposite to the turn. The pilot must also weight shift and lean towards the opposite side of the turn at the same time.

The exit should be performed gradually and smoothly so that the changes in pressure and speed can be noted.

When exiting the spiral, the glider will briefly experience an asymmetrical acceleration and dive, depending on how the manoeuvre was carried out.

Practise these manoeuvres at sufficient altitude and carefully.

### 5.4 SLOW DESCENT TECHNIQUE

This technique allows descent without straining the wing or taxing the pilot. Glide normally while searching for descending air and begin to turn as if climbing in a thermal, but with the intention to sink.

Common sense has to be used to avoid dangerous areas of rotor when looking for descending air. Safety first!

## 6. SPECIAL METHODS

### 6.1 TOWING

The HOOK 6 does not experience any problem whilst being towed. Only qualified winch personnel should handle the certified equipment to carry out this operation. The wing must be inflated similarly as during a normal take off.

It is important to use the brakes to correct the flight path alignment, especially in the first phase of the tow. Since the wing is subject to a slow airspeed and with a high positive angle of attack, we must make any corrections with a high degree of feel and delicacy, in order to avoid a stall.



### 6.2 ACROBATIC FLIGHT

Although the HOOK 6 was tested by expert acrobatic pilots in extreme situations, it was not designed for it. We do not recommend using this glider for acrobatic flying!!!

We consider acrobatic flights to be any form of piloting different than standard flights. Learning acrobatic manoeuvres should be conducted under the supervision of qualified instructors within a school environment and over water with all safety/rescue elements in place. Centrifugal forces as high as 4 to 5 g can be exerted on the body and wing during extreme manoeuvres.

## 7. CARE AND MAINTENANCE

### 7.1 MAINTENANCE

Careful maintenance of your equipment will ensure continued top performance. Apart from the general checks, we recommend actively maintaining your equipment.

A pre-flight check is obligatory before each flight.

If there is any damage to the equipment or you suspect any areas of the wing are susceptible to wear, you should inspect these and act accordingly.

Niviuk we are firmly committed to make technology accessible to all pilots. Therefore, our wings are equipped with the latest technological advances gained from the experience of our R&D team. Thanks to these new technologies, paragliders are gaining more safety and performance, which requires greater care of the materials.



**IMPORTANT:** it is critical to avoid any kind of impact or dragging the leading edge on the ground. This part is reinforced with very durable and strong Nitinol rods that can be easily replaced. Dragging and/or hitting the leading edge can cause serious damage to the fabric, which is much more complicated and costly to repair.

The fabric and the lines do not need to be washed. If they become dirty, clean them with a soft damp cloth, using only water. Do not use detergents or other chemicals.

If your wing is wet from contact with water, place it in a dry area, air it and keep it away from direct sunlight.

Direct sunlight may damage the wing's materials and cause premature aging. After landing, do not leave the wing exposed to the sun. Pack it properly and stow it away in its backpack.

If you fly in sandy areas, avoid getting sand in the cells or down into the trailing edge. At the end of the flight, empty any sand that is in your wing. The openings at the end of the wingtips make this much easier.

If your wing is wet from contact with salt water, immerse it in fresh water and dry it away from direct sunlight.

## 7.2 STORAGE

It is important for the wing to be correctly folded when stored. Keep it in the in a cool, dry place away from solvents, fuels, oils.

Do not leave your gear inside a car boot, as cars left in the sun can become very hot. A rucksack can reach temperatures up to 60°C.

Weight should not be laid on top of the equipment.

It is very important to pack the wing correctly before storage.

In case of long-term storage, it is advisable, if possible, that the wing is not compressed and it should be stored loosely without direct contact with the ground. Humidity and heating can have an adverse effect on the equipment.

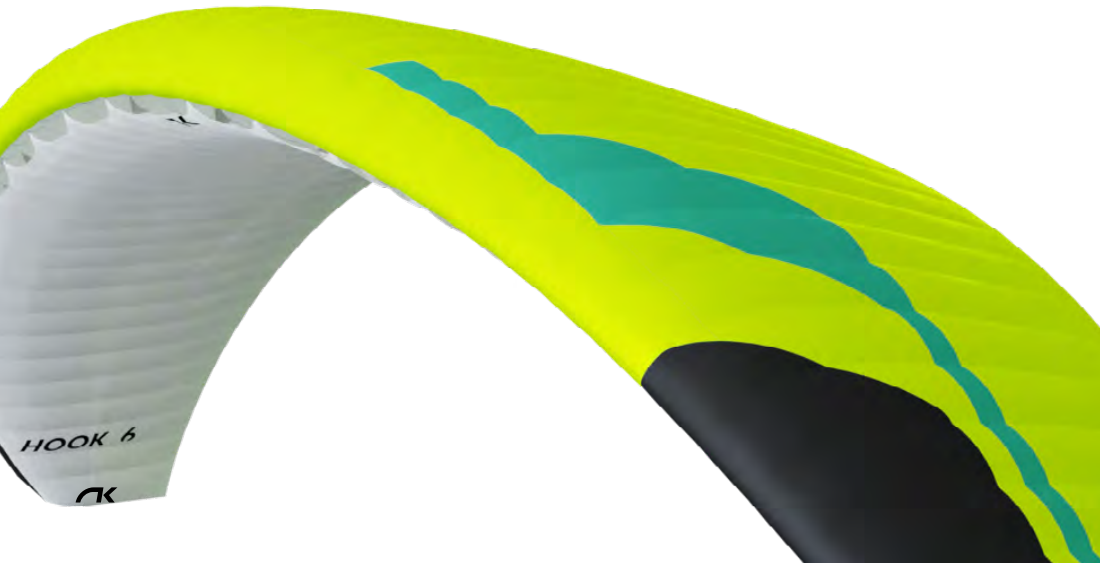

## 7.3 CHECKS AND INSPECTIONS

### Inspections

The HOOK 6 must be periodically serviced. An inspection must be scheduled every 100 flying hours or every two years whichever comes first (EN/LTF norm).

We strongly recommend that any repairs should be done in a specialist repair shop by qualified personnel.

This will guarantee the airworthiness and continued certification of your HOOK 6.

A thorough pre-flight check must be performed before every flight.

### Checking unsheathed lines

The HOOK 6 is fitted with unsheathed lines. Their durability conforms to unsheathed line standards. Their strength is guaranteed and their resistance to UV is one of the highest in this type of lines.

## 7.4 REPAIRS

In the case of small tears, you can temporarily repair these by using the Ripstop tape included in the repair kit, as long as no stitching is required to mend the fabric.

Any other tears or repairs should be done in a specialist repair shop by qualified personnel.

Damaged lines must be repaired or exchanged immediately.

Please refer to the line plan at the end of this manual.

We recommend any inspection or repair is performed by a Niviuk professional in our official workshop:

<https://niviuk.com/en/niviuk-service-form>

Any modification of the glider made in an external workshop will invalidate the guarantee of the product. Niviuk cannot be held responsible for any issues or damage resulting from modifications or repairs carried out by unqualified professionals or who are not approved by the manufacturer.

## 8. SAFETY AND RESPONSIBILITY

It is well known that free-flying with a paramotor or trike is considered a high-risk sport, where safety depends on the person who is practicing it.

Incorrect use of this equipment may cause severe, life-changing injuries to the pilot, or even death.

Manufacturers and dealers cannot be held responsible for your decisions, actions or accidents that may result from participating in this sport.

You must not use this equipment if you have not been properly trained to use it. Do not take advice or accept any informal training from anyone who is not properly qualified as a flight instructor.

## 9. GUARANTEE

The equipment and components are covered by a 2-year warranty against any manufacturing defect.

The warranty does not cover misuse of the equipment.

Any modification to the paraglider or its components invalidates the guarantee and the certification.

If you notice a fault or defect on your paraglider, contact Niviuk immediately for a full inspection.



# ANNEXES

# 10. ANNEXES

## 10.1 Technical specifications

			<b>20</b>	<b>22</b>	<b>24</b>	<b>26</b>	<b>28</b>	<b>31</b>
<b>Cells</b>	Number		47	47	47	47	47	47
<b>Aspect ratio</b>	Flat		5,3	5,3	5,3	5,3	5,3	5,3
	Projected		4	4	4	4	4	4
<b>Area</b>	Flat	m2	20	22	24	26	28	31
	Projected	m2	17,15	18,87	20,59	22,3	24,02	26,59
<b>Span</b>	Flat	m	10,3	10,8	11,28	11,74	12,18	12,82
<b>Chord</b>	Max	m	2,43	2,55	2,66	2,77	2,87	3,02
<b>Lines</b>	Total	m	205	215	226	235	244	258
	Main		2-1/3/2	2-1/3/2	2-1/3/2	2-1/3/2	2-1/3/2	2-1/3/2
<b>Risers</b>	Number	3+1	A-A'/B/C	A-A'/B/C	A-A'/B/C	A-A'/B/C	A-A'/B/C	A-A'/B/C
	Speed-bar	mm	145	145	145	145	145	145
<b>Glider weight</b>		kg	3,97	4,2	4,5	4,8	5,1	5,5
<b>Total weight in flight</b>	Min-Max	kg	55-70	60-80	70-92	80-105	95-120	110-135
<b>Certification</b>			EN/LTF B	EN/LTF B	EN/LTF B	EN/LTF B	EN/LTF B	EN/LTF B

The total weight of the wing may differ ±2% due to variations in the weight of the fabric supplied by the manufacturers.

## 10.2 Colours



<b>NEON</b>	SB1	PINK	TOP	REF: 19-2047
	SB2	WHITE	BOTTOM - ALL WHITE	REF: 001
	SB3	SPECTRA GREEN	HORN	REF: 17-5335
	SB4	WHITE	SHADOW	REF: 001



<b>MATRIX</b>	SB1	LIMA	TOP	REF: 500
	SB2	WHITE	BOTTOM - ALL WHITE	REF: 001
	SB3	BLACK	HORN	REF: 102
	SB4	SPECTRA GREEN	SHADOW	REF: 17-5335



<b>TEKNO</b>	SB1	SLATE BLUE	TOP	REF: 317
	SB2	WHITE	BOTTOM - ALL WHITE	REF: 001
	SB3	GOLD	HORN	REF: 939
	SB4	WHITE	SHADOW	REF: 001

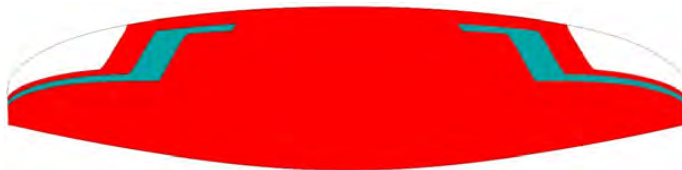

<b>SPICY</b>	SB1	DRAGON RED	TOP	REF: 636
	SB2	WHITE	BOTTOM - ALL WHITE	REF: 001
	SB3	WHITE	HORN	REF: 001
	SB4	SPECTRA GREEN	SHADOW	REF: 17-5335



## 10.3 Materials

CANOPY	FABRIC CODE	SUPPLIER
UPPER SURFACE	HYPERAIRTEX-41 / HYPERAIRTEX-36	DOMINICO TEX CO (Korea)
BOTTOM SURFACE	HYPERAIRTEX-36	DOMINICO TEX CO (Korea)
PROFILES	30 DFM	DOMINICO TEX CO (Korea)
DIAGONALS	30 DFM	DOMINICO TEX CO (Korea)
LOOPS	LKI - 12	KOLON IND. (KOREA)
REINFORCEMENT LOOPS	RIPSTOP FABRIC	DOMINICO TEX CO (Korea)
TRAILING EDGE REINFORCEMENT	MYLAR	D-P (GERMANY)
RIBS REINFORCEMENT	LTN-0.8/0.5 STICK	SPORTWARE CO.CHINA
THREAD	SERAFIL 60	AMAN (GERMANY)
SUSPENSION LINES	FABRIC CODE	SUPPLIER
UPPER CASCADES	A-8001/U 50	EDELRID (GERMANY)
UPPER CASCADES	A-8001/U 70	EDELRID (GERMANY)
UPPER CASCADES	A-8001/U 130	EDELRID (GERMANY)
UPPER CASCADES	TNL-80	TEIJIM LIMITED (JAPAN)
MIDDLE CASCADES	A-8001/U 50	EDELRID (GERMANY)
MIDDLE CASCADES	TNL-80	TEIJIM LIMITED (JAPAN)
MIDDLE CASCADES	TNL-140	TEIJIM LIMITED (JAPAN)
MIDDLE CASCADES	TNL-220	TEIJIM LIMITED (JAPAN)
MAIN	TNL-80	TEIJIM LIMITED (JAPAN)
MAIN	TNL-280	TEIJIM LIMITED (JAPAN)
MAIN BREAK	TARAX-200	EDELRID (GERMANY)
THREAD	SERAFIL 60	AMAN (GERMANY)
RISERS	FABRIC CODE	SUPPLIER
MATERIAL	3455	COUSIN (FRANCE)
COLOR INDICATOR	210D	TECNI SANGLES (FRANCE)
THREAD	V138	COATS (ENGLAND)
MAILLONS	3.5	ANSUNG PRECISION (KOREA)
PULLEYS	SB15	RONSTAN (AUSTRALIA)

## 10.4 Line plan

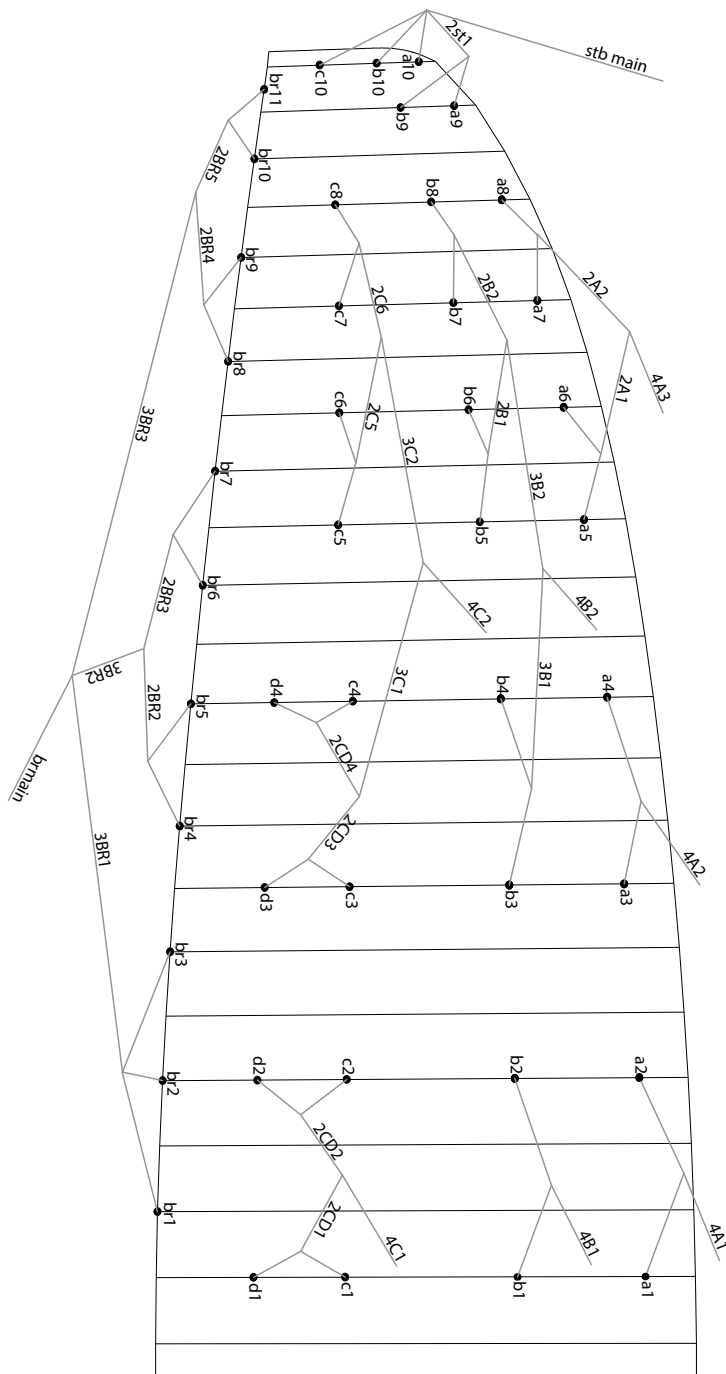

### LINE REPLACEMENT

The use of new high performance materials in modern wings is now common. The advantages of using these materials in terms of performance are widely acknowledged as part of our sport's evolution. However, along with those technological advances come additional responsibilities which cannot be avoided. As a result, line inspection and replacement must be carried out more frequently. That increased frequency appears to be encouraging some pilots to try to perform line replacement themselves.

**WE STRONGLY RECOMMEND ANY LINE REPLACEMENT IS PERFORMED BY AN AUTHORISED SPECIALIST ONLY.**

Ultimately, if the pilot decides to perform any line replacement without professional oversight they therefore assume all responsibility. In this case, these guidelines will have to be followed.

#### BEFORE REMOVING ANY LINES, CHECK:

- That the line plan is correct according to the glider model and size.
- That the line kit is complete and correct.
- Never assume but always check each individual line for the correct specification.

#### AFTER CONFIRMING THAT ALL LINES ARE CORRECT:

- Fit the new line(s) WITHOUT removing the label.
- Once replaced, measure each line length to confirm the correct measurement.
- Inflate the wing to check for any irregularities.
- The line labels may then be removed but NOT BEFORE completion of the line replacement.

Niviuk strongly recommends for any line replacement to be carried out by an authorised professional only, and will not accept responsibility for any damage or injury caused as a result of incorrect re-assembly.

# 10.5 Riser plan

<b>A</b>	<b>A'</b>	<b>B</b>	<b>C</b>
4A1	4A3	4B1	4C1
4A2		4B2	4C2
		stb main	

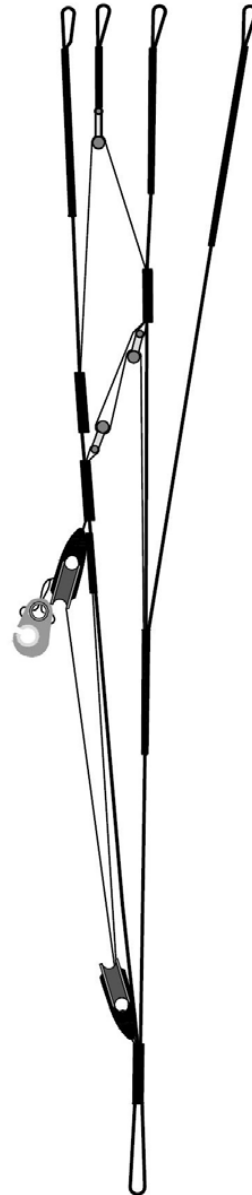

## 10.6 Line measurements by size

### HOOK 6 20

REF.	MAT.	kg	COLOR	mm	REF.	MAT.	kg	COLOR	mm	REF.	MAT.	kg	COLOR	mm	MAT.	kg	COLOR	mm	REF.	MAT.	kg	COLOR	mm	
<b>A</b>					<b>B</b>					<b>C</b>					<b>D</b>					<b>BRAKE</b>				
a1	8001/U	130	BLUE	1761	b1	8001/U	130	BLUE	1740	c1	8001/U	50	BLUE	1004	d1	8001/U	50	BLUE	1112	br1	TNL	80	RED	1721
a2	8001/U	130	BLUE	1718	b2	8001/U	130	BLUE	1695	c2	8001/U	50	BLUE	979	d2	8001/U	50	BLUE	1083	br2	TNL	80	RED	1510
a3	8001/U	130	BLUE	1643	b3	8001/U	130	BLUE	1626	c3	8001/U	50	BLUE	928	d3	8001/U	50	BLUE	1029	br3	TNL	80	RED	1446
a4	8001/U	130	BLUE	1607	b4	8001/U	130	BLUE	1552	c4	8001/U	50	BLUE	862	d4	8001/U	50	BLUE	953	br4	TNL	80	RED	851
a5	8001/U	70	BLUE	1018	b5	8001/U	70	BLUE	997	c5	8001/U	50	BLUE	899						br5	TNL	80	RED	704
a6	8001/U	70	BLUE	878	b6	8001/U	70	BLUE	903	c6	8001/U	50	BLUE	812						br6	TNL	80	RED	700
a7	8001/U	70	BLUE	967	b7	8001/U	70	BLUE	898	c7	8001/U	50	BLUE	778						br7	TNL	80	RED	751
a8	8001/U	70	BLUE	905	b8	8001/U	70	BLUE	893	c8	8001/U	50	BLUE	794						br8	TNL	80	RED	678
a9	8001/U	50	BLUE	722	b9	8001/U	50	BLUE	697	c10	8001/U	50	BLUE	1381						br9	TNL	80	RED	552
a10	8001/U	50	BLUE	1317	b10	8001/U	50	BLUE	1316										br10	TNL	80	RED	549	
																			br11	TNL	80	RED	460	
2A1	TNL	140	GREEN	1028	2B1	TNL	140	BLUE	887	2CD1	TNL	140	BLUE	533						2BR2	TNL	80	Red	737
2A2	TNL	140	GREEN	842	2B2	TNL	80	BLUE	846	2CD2	TNL	140	BLUE	518						2BR3	TNL	80	RED	690
2ST1	8001/U	50	BLUE	699	3B1	TNL	220	BLUE	2094	2CD3	TNL	140	BLUE	524						2BR4	TNL	80	RED	578
					3B2	TNL	140	BLUE	1721	2CD4	TNL	80	BLUE	481						2BR5	TNL	80	RED	475
										2C5	TNL	80	BLUE	823						3BR1	TNL	80	RED	2297
										2C6	TNL	80	BLUE	826						3BR2	TNL	80	RED	2161
										3C1	TNL	220	BLUE	1808						3BR3	TNL	80	RED	2335
										3C2	TNL	80	BLUE	1392										
4A1	TNL	280	GREEN	4114	4B1	TNL	280	BLUE	4035	4C1	TNL	280	BLUE	4282						BRMAIN	TARAX	200	RED	2637
4A2	TNL	280	GREEN	4153	4B2	TNL	280	BLUE	2036	4C2	TNL	280	BLUE	2586						KNOT POINT:				2437
4A3	TNL	280	GREEN	3682	STB MAIN	TNL	80	RED	3818															

**HOOK 6 22**

REF.	MAT.	kg	COLOR	mm	REF.	MAT.	kg	COLOR	mm	REF.	MAT.	kg	COLOR	mm	MAT.	kg	COLOR	mm	REF.	MAT.	kg	COLOR	mm	
<b>A</b>					<b>B</b>					<b>C</b>					<b>D</b>					<b>BRAKE</b>				
a1	8001/U	130	BLUE	1847	b1	8001/U	130	BLUE	1825	c1	8001/U	50	BLUE	1053	d1	8001/U	50	BLUE	1166	br1	TNL	80	RED	1805
a2	8001/U	130	BLUE	1803	b2	8001/U	130	BLUE	1778	c2	8001/U	50	BLUE	1027	d2	8001/U	50	BLUE	1136	br2	TNL	80	RED	1583
a3	8001/U	130	BLUE	1724	b3	8001/U	130	BLUE	1705	c3	8001/U	50	BLUE	974	d3	8001/U	50	BLUE	1079	br3	TNL	80	RED	1516
a4	8001/U	130	BLUE	1686	b4	8001/U	130	BLUE	1628	c4	8001/U	50	BLUE	905	d4	8001/U	50	BLUE	1000	br4	TNL	80	RED	892
a5	8001/U	70	BLUE	1068	b5	8001/U	70	BLUE	1046	c5	8001/U	50	BLUE	943						br5	TNL	80	RED	738
a6	8001/U	70	BLUE	921	b6	8001/U	70	BLUE	947	c6	8001/U	50	BLUE	851						br6	TNL	80	RED	734
a7	8001/U	70	BLUE	1014	b7	8001/U	70	BLUE	942	c7	8001/U	50	BLUE	817						br7	TNL	80	RED	787
a8	8001/U	70	BLUE	948	b8	8001/U	70	BLUE	936	c8	8001/U	50	BLUE	833						br8	TNL	80	RED	706
a9	8001/U	50	BLUE	757	b9	8001/U	50	BLUE	731	c10	8001/U	50	BLUE	1448						br9	TNL	80	RED	574
a10	8001/U	50	BLUE	1381	b10	8001/U	50	BLUE	1380										br10	TNL	80	RED	571	
																			br11	TNL	80	RED	485	
2A1	TNL	140	GREEN	1078	2B1	TNL	140	BLUE	930	2CD1	TNL	140	BLUE	559					2BR2	TNL	80	Red	773	
2A2	TNL	140	GREEN	882	2B2	TNL	80	BLUE	887	2CD2	TNL	140	BLUE	544					2BR3	TNL	80	RED	724	
2ST1	8001/U	50	BLUE	733	3B1	TNL	220	BLUE	2196	2CD3	TNL	140	BLUE	550					2BR4	TNL	80	RED	601	
					3B2	TNL	140	BLUE	1804	2CD4	TNL	80	BLUE	504					2BR5	TNL	80	RED	498	
										2C5	TNL	80	BLUE	864					3BR1	TNL	80	RED	2406	
										2C6	TNL	80	BLUE	865					3BR2	TNL	80	RED	2263	
										3C1	TNL	220	BLUE	1896					3BR3	TNL	80	RED	2455	
										3C2	TNL	80	BLUE	1459										
4A1	TNL	280	GREEN	4338	4B1	TNL	280	BLUE	4253	4C1	TNL	280	BLUE	4514					BRMAIN	TARAX	200	RED	2741	
4A2	TNL	280	GREEN	4379	4B2	TNL	280	BLUE	2159	4C2	TNL	280	BLUE	2735					KNOT POINT:				2541	
4A3	TNL	280	GREEN	3885	STB MAIN	TNL	80	RED	4026															

## HOOK 6 24

REF.	MAT.	kg	COLOR	mm	REF.	MAT.	kg	COLOR	mm	REF.	MAT.	kg	COLOR	mm	MAT.	kg	COLOR	mm	REF.	MAT.	kg	COLOR	mm	
A					B					C					D					BRAKE				
a1	8001/U	130	BLUE	1929	b1	8001/U	130	BLUE	1906	c1	8001/U	50	BLUE	1100	d1	8001/U	50	BLUE	1218	br1	TNL	80	RED	1885
a2	8001/U	130	BLUE	1883	b2	8001/U	130	BLUE	1858	c2	8001/U	50	BLUE	1073	d2	8001/U	50	BLUE	1187	br2	TNL	80	RED	1654
a3	8001/U	130	BLUE	1800	b3	8001/U	130	BLUE	1781	c3	8001/U	50	BLUE	1017	d3	8001/U	50	BLUE	1127	br3	TNL	80	RED	1584
a4	8001/U	130	BLUE	1760	b4	8001/U	130	BLUE	1700	c4	8001/U	50	BLUE	945	d4	8001/U	50	BLUE	1044	br4	TNL	80	RED	932
a5	8001/U	70	BLUE	1115	b5	8001/U	70	BLUE	1092	c5	8001/U	50	BLUE	985						br5	TNL	80	RED	771
a6	8001/U	70	BLUE	961	b6	8001/U	70	BLUE	989	c6	8001/U	50	BLUE	888						br6	TNL	80	RED	767
a7	8001/U	70	BLUE	1059	b7	8001/U	70	BLUE	984	c7	8001/U	50	BLUE	853						br7	TNL	80	RED	822
a8	8001/U	70	BLUE	990	b8	8001/U	70	BLUE	978	c8	8001/U	50	BLUE	870						br8	TNL	80	RED	742
a9	8001/U	50	BLUE	791	b9	8001/U	50	BLUE	763	c10	8001/U	50	BLUE	1512						br9	TNL	80	RED	605
a10	8001/U	50	BLUE	1442	b10	8001/U	50	BLUE	1441										br10	TNL	80	RED	601	
																			br11	TNL	80	RED	503	
2A1	TNL	140	GREEN	1127	2B1	TNL	140	BLUE	972	2CD1	TNL	140	BLUE	584					2BR2	TNL	80	Red	807	
2A2	TNL	140	GREEN	920	2B2	TNL	80	BLUE	926	2CD2	TNL	140	BLUE	568					2BR3	TNL	80	RED	756	
2ST1	8001/U	50	BLUE	766	3B1	TNL	220	BLUE	2294	2CD3	TNL	140	BLUE	574					2BR4	TNL	80	RED	633	
					3B2	TNL	140	BLUE	1884	2CD4	TNL	80	BLUE	525					2BR5	TNL	80	RED	520	
										2C5	TNL	80	BLUE	903					3BR1	TNL	80	RED	2517	
										2C6	TNL	80	BLUE	903					3BR2	TNL	80	RED	2367	
										3C1	TNL	220	BLUE	1981					3BR3	TNL	80	RED	2558	
										3C2	TNL	80	BLUE	1523										
4A1	TNL	280	GREEN	4552	4B1	TNL	280	BLUE	4462	4C1	TNL	280	BLUE	4735					BRMAIN	TARAX	200	RED	2903	
4A2	TNL	280	GREEN	4595	4B2	TNL	280	BLUE	2276	4C2	TNL	280	BLUE	2878					KNOT POINT:				2703	
4A3	TNL	280	GREEN	4078	STB MAIN	TNL	80	RED	4224															

**HOOK 6 26**

REF.	MAT.	kg	COLOR	mm	REF.	MAT.	kg	COLOR	mm	REF.	MAT.	kg	COLOR	mm	MAT.	kg	COLOR	mm	REF.	MAT.	kg	COLOR	mm	
<b>A</b>					<b>B</b>					<b>C</b>					<b>D</b>					<b>BRAKE</b>				
a1	8001/U	130	BLUE	2007	b1	8001/U	130	BLUE	1983	c1	8001/U	50	BLUE	1145	d1	8001/U	50	BLUE	1267	br1	TNL	80	RED	1962
a2	8001/U	130	BLUE	1961	b2	8001/U	130	BLUE	1935	c2	8001/U	50	BLUE	1117	d2	8001/U	50	BLUE	1235	br2	TNL	80	RED	1722
a3	8001/U	130	BLUE	1873	b3	8001/U	130	BLUE	1854	c3	8001/U	50	BLUE	1059	d3	8001/U	50	BLUE	1173	br3	TNL	80	RED	1649
a4	8001/U	130	BLUE	1833	b4	8001/U	130	BLUE	1770	c4	8001/U	50	BLUE	983	d4	8001/U	50	BLUE	1087	br4	TNL	80	RED	969
a5	8001/U	70	BLUE	1161	b5	8001/U	70	BLUE	1137	c5	8001/U	50	BLUE	1025						br5	TNL	80	RED	803
a6	8001/U	70	BLUE	1001	b6	8001/U	70	BLUE	1031	c6	8001/U	50	BLUE	925						br6	TNL	80	RED	798
a7	8001/U	70	BLUE	1103	b7	8001/U	70	BLUE	1024	c7	8001/U	50	BLUE	888						br7	TNL	80	RED	857
a8	8001/U	70	BLUE	1031	b8	8001/U	70	BLUE	1018	c8	8001/U	50	BLUE	906						br8	TNL	80	RED	772
a9	8001/U	50	BLUE	823	b9	8001/U	50	BLUE	795	c10	8001/U	50	BLUE	1574						br9	TNL	80	RED	629
a10	8001/U	50	BLUE	1501	b10	8001/U	50	BLUE	1500											br10	TNL	80	RED	626
																				br11	TNL	80	RED	525
2A1	TNL	140	GREEN	1172	2B1	TNL	140	BLUE	1011	2CD1	TNL	140	BLUE	607						2BR2	TNL	80	Red	840
2A2	TNL	140	GREEN	959	2B2	TNL	80	BLUE	965	2CD2	TNL	140	BLUE	593						2BR3	TNL	80	RED	788
2ST1	8001/U	50	BLUE	797	3B1	TNL	220	BLUE	2386	2CD3	TNL	140	BLUE	597						2BR4	TNL	80	RED	659
					3B2	TNL	140	BLUE	1962	2CD4	TNL	80	BLUE	548						2BR5	TNL	80	RED	542
										2C5	TNL	80	BLUE	939						3BR1	TNL	80	RED	2616
										2C6	TNL	80	BLUE	941						3BR2	TNL	80	RED	2464
										3C1	TNL	220	BLUE	2061						3BR3	TNL	80	RED	2665
										3C2	TNL	80	BLUE	1587										
4A1	TNL	280	GREEN	4758	4B1	TNL	280	BLUE	4664	4C1	TNL	280	BLUE	4949						BRMAIN	TARAX	200	RED	3055
4A2	TNL	280	GREEN	4806	4B2	TNL	280	BLUE	2393	4C2	TNL	280	BLUE	3020						KNOT POINT:				2855
4A3	TNL	280	GREEN	4270	STB MAIN	TNL	80	RED	4423															

**HOOK 6 28**

REF.	MAT.	kg	COLOR	mm	REF.	MAT.	kg	COLOR	mm	REF.	MAT.	kg	COLOR	mm	MAT.	kg	COLOR	mm	REF.	MAT.	kg	COLOR	mm	
<b>A</b>					<b>B</b>					<b>C</b>					<b>D</b>					<b>BRAKE</b>				
a1	8001/U	130	BLUE	2082	b1	8001/U	130	BLUE	2057	c1	8001/U	50	BLUE	1188	d1	8001/U	50	BLUE	1315	br1	TNL	80	RED	2036
a2	8001/U	130	BLUE	2036	b2	8001/U	130	BLUE	2009	c2	8001/U	50	BLUE	1159	d2	8001/U	50	BLUE	1282	br2	TNL	80	RED	1787
a3	8001/U	130	BLUE	1944	b3	8001/U	130	BLUE	1923	c3	8001/U	50	BLUE	1099	d3	8001/U	50	BLUE	1217	br3	TNL	80	RED	1713
a4	8001/U	130	BLUE	1903	b4	8001/U	130	BLUE	1838	c4	8001/U	50	BLUE	1021	d4	8001/U	50	BLUE	1128	br4	TNL	80	RED	1005
a5	8001/U	70	BLUE	1205	b5	8001/U	70	BLUE	1180	c5	8001/U	50	BLUE	1063						br5	TNL	80	RED	833
a6	8001/U	70	BLUE	1039	b6	8001/U	70	BLUE	1070	c6	8001/U	50	BLUE	960						br6	TNL	80	RED	829
a7	8001/U	70	BLUE	1144	b7	8001/U	70	BLUE	1063	c7	8001/U	50	BLUE	921						br7	TNL	80	RED	890
a8	8001/U	70	BLUE	1070	b8	8001/U	70	BLUE	1057	c8	8001/U	50	BLUE	940						br8	TNL	80	RED	801
a9	8001/U	50	BLUE	854	b9	8001/U	50	BLUE	825	c10	8001/U	50	BLUE	1633						br9	TNL	80	RED	653
a10	8001/U	50	BLUE	1558	b10	8001/U	50	BLUE	1556										br10	TNL	80	RED	649	
																			br11	TNL	80	RED	545	
2A1	TNL	140	GREEN	1216	2B1	TNL	140	BLUE	1049	2CD1	TNL	140	BLUE	629					2BR2	TNL	80	Red	872	
2A2	TNL	140	GREEN	996	2B2	TNL	80	BLUE	1003	2CD2	TNL	140	BLUE	616					2BR3	TNL	80	RED	818	
2ST1	8001/U	50	BLUE	827	3B1	TNL	220	BLUE	2475	2CD3	TNL	140	BLUE	620					2BR4	TNL	80	RED	683	
					3B2	TNL	140	BLUE	2037	2CD4	TNL	80	BLUE	569					2BR5	TNL	80	RED	562	
										2C5	TNL	80	BLUE	974					3BR1	TNL	80	RED	2712	
										2C6	TNL	80	BLUE	977					3BR2	TNL	80	RED	2557	
										3C1	TNL	220	BLUE	2138					3BR3	TNL	80	RED	2769	
										3C2	TNL	80	BLUE	1648										
4A1	TNL	280	GREEN	4956	4B1	TNL	280	BLUE	4857	4C1	TNL	280	BLUE	5154					BRMAIN	TARAX	200	RED	3157	
4A2	TNL	280	GREEN	5009	4B2	TNL	280	BLUE	2507	4C2	TNL	280	BLUE	3157					KNOT POINT:				2957	
4A3	TNL	280	GREEN	4455	STB MAIN	TNL	80	RED	4615															

**HOOK 6 31**

REF.	MAT.	kg	COLOR	mm	REF.	MAT.	kg	COLOR	mm	REF.	MAT.	kg	COLOR	mm	MAT.	kg	COLOR	mm	REF.	MAT.	kg	COLOR	mm	
<b>A</b>					<b>B</b>					<b>C</b>					<b>D</b>					<b>BRAKE</b>				
a1	8001/U	130	BLUE	2189	b1	8001/U	130	BLUE	2163	c1	8001/U	50	BLUE	1250	d1	8001/U	50	BLUE	1384	br1	TNL	80	RED	2141
a2	8001/U	130	BLUE	2144	b2	8001/U	130	BLUE	2116	c2	8001/U	50	BLUE	1220	d2	8001/U	50	BLUE	1349	br2	TNL	80	RED	1881
a3	8001/U	130	BLUE	2045	b3	8001/U	130	BLUE	2023	c3	8001/U	50	BLUE	1156	d3	8001/U	50	BLUE	1281	br3	TNL	80	RED	1804
a4	8001/U	130	BLUE	2003	b4	8001/U	130	BLUE	1935	c4	8001/U	50	BLUE	1074	d4	8001/U	50	BLUE	1187	br4	TNL	80	RED	1057
a5	8001/U	70	BLUE	1268	b5	8001/U	70	BLUE	1242	c5	8001/U	50	BLUE	1119						br5	TNL	80	RED	877
a6	8001/U	70	BLUE	1094	b6	8001/U	70	BLUE	1127	c6	8001/U	50	BLUE	1011						br6	TNL	80	RED	872
a7	8001/U	70	BLUE	1204	b7	8001/U	70	BLUE	1118	c7	8001/U	50	BLUE	969						br7	TNL	80	RED	938
a8	8001/U	70	BLUE	1127	b8	8001/U	70	BLUE	1113	c8	8001/U	50	BLUE	989						br8	TNL	80	RED	842
a9	8001/U	50	BLUE	899	b9	8001/U	50	BLUE	868	c10	8001/U	50	BLUE	1718						br9	TNL	80	RED	688
a10	8001/U	50	BLUE	1639	b10	8001/U	50	BLUE	1638											br10	TNL	80	RED	684
																				br11	TNL	80	RED	574
2A1	TNL	140	GREEN	1279	2B1	TNL	140	BLUE	1104	2CD1	TNL	140	BLUE	660						2BR2	TNL	80	Red	917
2A2	TNL	140	GREEN	1049	2B2	TNL	80	BLUE	1058	2CD2	TNL	140	BLUE	650						2BR3	TNL	80	RED	861
2ST1	8001/U	50	BLUE	870	3B1	TNL	220	BLUE	2603	2CD3	TNL	140	BLUE	652						2BR4	TNL	80	RED	719
					3B2	TNL	140	BLUE	2145	2CD4	TNL	80	BLUE	599						2BR5	TNL	80	RED	592
										2C5	TNL	80	BLUE	1024						3BR1	TNL	80	RED	2849
										2C6	TNL	80	BLUE	1029						3BR2	TNL	80	RED	2691
										3C1	TNL	220	BLUE	2249						3BR3	TNL	80	RED	2918
										3C2	TNL	80	BLUE	1736										
4A1	TNL	400	GREEN	5240	4B1	TNL	280	BLUE	5136	4C1	TNL	280	BLUE	5449						BRMAIN	TARAX	200	RED	3336
4A2	TNL	400	GREEN	5301	4B2	TNL	280	BLUE	2669	4C2	TNL	280	BLUE	3353						KNOT POINT:				3136
4A3	TNL	280	GREEN	4721	STB MAIN	TNL	80	RED	4891															

## 10.7 Total line length

### HOOK 6 20

LINES HEIGHT + RISER mm

	A	B	C	D	BR
1	6390	6289	6328	6436	6490
2	6347	6244	6288	6392	6279
3	6311	6256	6343	6444	6215
4	6275	6182	6235	6326	6212
5	6233	6134	6201		6065
6	6093	6040	6114		6014
7	5996	5996	6083		6065
8	5934	5991	6099		6054
9	5755	5730	5718		5928
10	5654	5653			5822
11					5733

RISERS LENGHT mm

A	A'	B	C	
500	500	500	500	STANDARD
380	398	418	500	ACCELERATED

### HOOK 6 22

LINES HEIGHT + RISER mm

	A	B	C	D	BR
1	6700	6593	6635	6748	6787
2	6656	6546	6594	6703	6565
3	6618	6561	6652	6757	6498
4	6580	6484	6538	6633	6495
5	6536	6433	6502		6341
6	6389	6334	6410		6288
7	6286	6288	6377		6341
8	6220	6282	6393		6329
9	6032	6007	5993		6197
10	5926	5926			6091
11					6005

RISERS LENGHT mm

A	A'	B	C	
500	500	500	500	STANDARD
355	380	403	500	ACCELERATED

### HOOK 6 24

LINES HEIGHT + RISER mm

	A	B	C	D	BR
1	6996	6882	6928	7046	7140
2	6950	6834	6885	6999	6909
3	6910	6851	6947	7057	6839
4	6870	6770	6827	6926	6835
5	6825	6717	6790		6674
6	6671	6614	6693		6619
7	6562	6565	6658		6674
8	6493	6559	6675		6662
9	6297	6269	6255		6525
10	6185	6184			6408
11					6310

RISERS LENGHT mm

A	A'	B	C	
500	500	500	500	STANDARD
355	380	403	500	ACCELERATED

## HOOK 6 26

LINES HEIGHT + RISER mm

	A	B	C	D	BR
1	7280	7162	7210	7332	7468
2	7234	7114	7168	7286	7228
3	7194	7134	7234	7348	7155
4	7154	7050	7110	7214	7154
5	7108	6997	7072		6988
6	6948	6891	6972		6931
7	6837	6840	6937		6990
8	6765	6834	6955		6977
9	6559	6532	6516		6834
10	6443	6443			6714
11					6613

RISERS LENGHT mm

A	A'	B	C	
500	500	500	500	STANDARD
355	380	403	500	ACCELERATED

## HOOK 6 28

LINES HEIGHT + RISER mm

	A	B	C	D	BR
1	7553	7428	7480	7607	7740
2	7507	7380	7438	7561	7491
3	7468	7405	7511	7629	7417
4	7427	7320	7383	7490	7417
5	7381	7266	7343		7245
6	7215	7156	7240		7187
7	7100	7105	7204		7248
8	7026	7099	7223		7236
9	6812	6783	6767		7088
10	6692	6690			6963
11					6859

RISERS LENGHT mm

A	A'	B	C	
500	500	500	500	STANDARD
355	380	403	500	ACCELERATED

## HOOK 6 31

LINES HEIGHT + RISER mm

	A	B	C	D	BR
1	7944	7813	7868	8002	8161
2	7899	7766	7828	7957	7901
3	7861	7795	7907	8032	7824
4	7819	7707	7773	7886	7827
5	7773	7653	7733		7647
6	7599	7538	7625		7586
7	7479	7485	7588		7652
8	7402	7480	7608		7641
9	7176	7145	7128		7487
10	7049	7048			7356
11					7246

RISERS LENGHT mm

A	A'	B	C	
500	500	500	500	STANDARD
355	380	403	500	ACCELERATED

## 10.8 Minimum strength of suspension lines

LINE REFERENCE	SIZE					
	20	22	24	26	28	31
<b>TNL-80</b>	21	24	27	31	35	40
<b>TNL-140</b>	40	45	52	60	68	77
<b>TNL-220</b>	61	70	81	92	105	119
<b>TNL-280</b>	77	88	101	116	132	149
<b>TNL-400</b>	93	106	122	139	159	179
<b>8001U-50</b>	16	18	21	23	27	30
<b>8001U-70</b>	18	20	24	27	31	35
<b>8001U-130</b>	36	41	47	53	61	69
<b>8001U-190</b>	63	72	83	94	108	121

Minimum resistance values in daN

Based on the original experimental resistance values of each suspension line material obtained in certification tests, a correction factor is applied depending on the material and its aging, resulting in the reference values shown in the table.

## 10.9 Maillon & Pulley

### DESCRIPTION

MAILLON	DELTA
CODE	3.5
MATERIAL	STAINLESS STEEL
SIZE	3 m/m
WEIGHT	5 G/PIECE
QUANTITY	8 PIECES
INSERTS	2 GREEN / 6 BLACK

### TECHNICAL SPECIFICATIONS

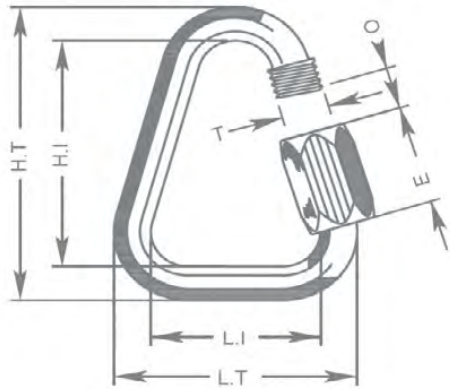

DIMENSIONS	mm
L.T.	22
L.I.	14
H.T.	37
H.I.	29
O	5
E	12
T	4
LOAD	KG
WORKING LIMIT	110
BREAKING	550

### MATERIAL

AISI 304 STAINLESS STEEL	STANDARD
--------------------------	----------

CLOSING APPLIED BY MANUAL & ENTIRE SCREWING OF THE NUT

TO GUARANTEE THE HIGHEST SAFETY (NO THREAD SHOULD BE OBVIOUS)

SYSTEMATIC CONTROL OF MAILLON QUICK-LINKS BEFORE EVERY FLIGHT

### DESCRIPTION PULLEY

PULLEY	20 M/M
CODE	RF25109
MATERIALS	STAINLESS STEEL
	NYLON
	CARBON ACETAL
BEARING	DELRIN®
WEIGHT	14 G/PIECE

### TECHNICAL SPECIFICATIONS

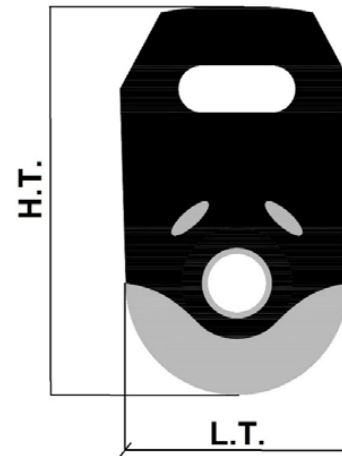

DIMENSIONS	mm
L.T.	20
H.T.	33
Ø	5 MAX
LOAD	KG
WORKING LIMIT	200
BREAKING	400

# 10.10 Certification

AIR TURQUOISE SA | PARA-TEST.COM

Route du Pré-au-Comte 8 • CH-1944 Villeneuve • +41 (0)21 955 65 65

Test laboratory for paragliders, paraglider harnesses and paraglider reserve parachutes



Classification: **B**

In accordance with standards EN 926-1:2015, EN 926-2:2013+A1:2021 and Nfl 2-565-20

Date of issue (DMY):

Manufacturer:

Model:

Serial number:

PG\_2025.2022

21.09.2022

Niviuk Gliders / Air Games S.L.

Hook 6 20

HOOK6201

## Configuration during flight tests

Paraglider		Accessories	
Maximum weight in flight (kg)	70	Range of speed system (cm)	13.7
Minimum weight in flight (kg)	55	Speed range using brakes (km/h)	14
Glider's weight (kg)	3.9	Total speed range with accessories (km/h)	25
Number of risers	3+1	Range of trimmers (cm)	0
Projected area (m2)	17.15		

### Harness used for testing (max weight)

Harness used for testing (max weight)		Inspections (whichever happens first)	
Harness type	ABS	every 100 hours of use or every 24 months (whichever happens first)	
Harness brand	Woody Valley	Warning! Before use refer to user's manual	
Harness model	Wani Light 2 M	Person or company having presented the glider for testing: <b>None</b>	
Harness to risers distance (cm)	43		
Distance between risers (cm)	40		

1 2 3 4 5 6 7 8 9 10 11 12 13 14 15 16 17 18 19 20 21 22 23  
A A A A A A A A A A A A A B A A A A A A A A 0

Sticker generated automatically by AIR TURQUOISE SA, valid without signature // Rev 07 | 04.03.2022 // ISO | 91.21 // Page 1 of 1

AIR TURQUOISE SA | PARA-TEST.COM

Route du Pré-au-Comte 8 • CH-1944 Villeneuve • +41 (0)21 955 65 65

Test laboratory for paragliders, paraglider harnesses and paraglider reserve parachutes



Classification: **B**

In accordance with standards EN 926-1:2015, EN 926-2:2013+A1:2021 and Nfl 2-565-20

Date of issue (DMY):

Manufacturer:

Model:

Serial number:

PG\_2005.2022

21.09.2022

Niviuk Gliders / Air Games S.L.

Hook 6 22

HOOK67-22

## Configuration during flight tests

Paraglider		Accessories	
Maximum weight in flight (kg)	80	Range of speed system (cm)	16.6
Minimum weight in flight (kg)	60	Speed range using brakes (km/h)	14
Glider's weight (kg)	4.1	Total speed range with accessories (km/h)	25
Number of risers	3+1	Range of trimmers (cm)	0
Projected area (m2)	18.87		

### Harness used for testing (max weight)

Harness used for testing (max weight)		Inspections (whichever happens first)	
Harness type	ABS	every 100 hours of use or every 24 months (whichever happens first)	
Harness brand	Advance	Warning! Before use refer to user's manual	
Harness model	Success 4 M	Person or company having presented the glider for testing: <b>None</b>	
Harness to risers distance (cm)	43		
Distance between risers (cm)	44		

1 2 3 4 5 6 7 8 9 10 11 12 13 14 15 16 17 18 19 20 21 22 23  
A A A A A A A A A A A A A B A A A A A A A A 0

Sticker generated automatically by AIR TURQUOISE SA, valid without signature // Rev 07 | 04.03.2022 // ISO | 91.21 // Page 1 of 1



Classification: **B**



In accordance with standards EN 926-1:2015, EN 926-2:2013+A1:2021 and NF L 2-565-20

Date of issue (DMY):

Manufacturer:

Model:

Serial number:

PG\_2006.2022

21.09.2022

Niviuk Gliders / Air Games S.L.

Hook 6 24

HOOK6724

Configuration during flight tests

Paraglider		Accessories	
Maximum weight in flight (kg)	<b>92</b>	Range of speed system (cm)	<b>16.7</b>
Minimum weight in flight (kg)	<b>70</b>	Speed range using brakes (km/h)	<b>14</b>
Glider's weight (kg)	<b>4.4</b>	Total speed range with accessories (km/h)	<b>25</b>
Number of risers	<b>3+1</b>	Range of trimmers (cm)	<b>0</b>
Projected area (m2)	<b>20.59</b>		
Harness used for testing (max weight)		Inspections (whichever happens first)	
Harness type	<b>ABS</b>	every 100 hours of use or every 24 months (whichever happens first)	
Harness brand	<b>Advance</b>	Warning! Before use refer to user's manual	
Harness model	<b>Success 4 M</b>	Person or company having presented the glider for testing: <b>None</b>	
Harness to risers distance (cm)	<b>43</b>		
Distance between risers (cm)	<b>44</b>		

1 2 3 4 5 6 7 8 9 10 11 12 13 14 15 16 17 18 19 20 21 22 23  
**A A A A A A A A A A A A A B A A A A A A A A 0**



Classification: **B**



In accordance with standards EN 926-1:2015, EN 926-2:2013+A1:2021 and NF L 2-565-20

Date of issue (DMY):

Manufacturer:

Model:

Serial number:

PG\_2007.2022

21.09.2022

Niviuk Gliders / Air Games S.L.

Hook 6 26

HOOK6726

Configuration during flight tests

Paraglider		Accessories	
Maximum weight in flight (kg)	<b>105</b>	Range of speed system (cm)	<b>16.9</b>
Minimum weight in flight (kg)	<b>80</b>	Speed range using brakes (km/h)	<b>14</b>
Glider's weight (kg)	<b>4.7</b>	Total speed range with accessories (km/h)	<b>25</b>
Number of risers	<b>3+1</b>	Range of trimmers (cm)	<b>0</b>
Projected area (m2)	<b>22.3</b>		
Harness used for testing (max weight)		Inspections (whichever happens first)	
Harness type	<b>ABS</b>	every 100 hours of use or every 24 months (whichever happens first)	
Harness brand	<b>Dudek</b>	Warning! Before use refer to user's manual	
Harness model	<b>Zero Gravity M</b>	Person or company having presented the glider for testing: <b>None</b>	
Harness to risers distance (cm)	<b>43</b>		
Distance between risers (cm)	<b>46</b>		

1 2 3 4 5 6 7 8 9 10 11 12 13 14 15 16 17 18 19 20 21 22 23  
**A A A A A A A A A A A A A B A A A A A A A A 0**



Classification: **B**



In accordance with standards EN 926-1:2015, EN 926-2:2013+A1:2021 and NF L 2-565-20

Date of issue (DMY):

Manufacturer:

Model:

Serial number:

PG\_2024.2022

21.09.2022

Niviuk Gliders / Air Games S.L.

Hook 6 28

HOOK6281

### Configuration during flight tests

Paraglider		Accessories	
Maximum weight in flight (kg)	120	Range of speed system (cm)	16.1
Minimum weight in flight (kg)	95	Speed range using brakes (km/h)	14
Glider's weight (kg)	5.1	Total speed range with accessories (km/h)	25
Number of risers	3+1	Range of trimmers (cm)	0
Projected area (m2)	24.02		
<b>Harness used for testing (max weight)</b>		<b>Inspections (whichever happens first)</b>	
Harness type	ABS	every 100 hours of use or every 24 months (whichever happens first)	
Harness brand	Supair	Warning! Before use refer to user's manual	
Harness model	Evo XC 3 L	Person or company having presented the glider for testing: <b>None</b>	
Harness to risers distance (cm)	44		
Distance between risers (cm)	48		

1 2 3 4 5 6 7 8 9 10 11 12 13 14 15 16 17 18 19 20 21 22 23  
**A A B A A A A A A A A A B A A A A A A A A 0**



Classification: **B**



In accordance with standards EN 926-1:2015, EN 926-2:2013+A1:2021 and NF L 2-565-20

Date of issue (DMY):

Manufacturer:

Model:

Serial number:

PG\_2023.2022

21.09.2022

Niviuk Gliders / Air Games S.L.

Hook 6 31

HOOK63111

### Configuration during flight tests

Paraglider		Accessories	
Maximum weight in flight (kg)	135	Range of speed system (cm)	16.4
Minimum weight in flight (kg)	110	Speed range using brakes (km/h)	14
Glider's weight (kg)	5.5	Total speed range with accessories (km/h)	25
Number of risers	3+1	Range of trimmers (cm)	0
Projected area (m2)	26.59		
<b>Harness used for testing (max weight)</b>		<b>Inspections (whichever happens first)</b>	
Harness type	ABS	every 100 hours of use or every 24 months (whichever happens first)	
Harness brand	Supair	Warning! Before use refer to user's manual	
Harness model	Evo XC 3 L	Person or company having presented the glider for testing: <b>None</b>	
Harness to risers distance (cm)	44		
Distance between risers (cm)	48		

1 2 3 4 5 6 7 8 9 10 11 12 13 14 15 16 17 18 19 20 21 22 23  
**A A B A A A A A B A A A B A A A A A A A A 0**



**Niviuk Paragliders**

C/ Del Ter 6 - D

17165 La Celler de Ter - Girona - Spain

+34 972 422 878 | [info@niviuk.com](mailto:info@niviuk.com)

[www.niviuk.com](http://www.niviuk.com)